

SPEKTRUM



SPEKTRUM Health Care



SPEKTRUM Education



SPEKTRUM Laboratory



SPEKTRUM Green



SPEKTRUM Value

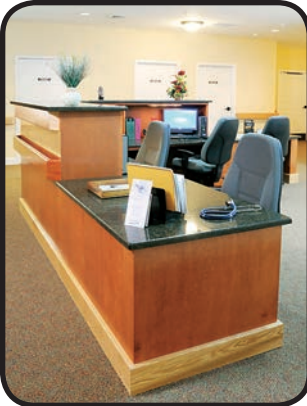

LAMINATE FURNITURE and Architectural Millwork



KEWAUNEE[®]

Laminate Products

Kewaunee Scientific Corporation

Setting the standard for quality furniture, workstations, fume hoods, and project performance since 1906.

Every Kewaunee project begins with a partnership. Whether you're an architect, a facility manager or designer, or an end user, we offer a team of professionals who will help you create the environment that best meets your needs.

You'll work with experienced sales representatives who form a nationwide network of consultants. They are backed by over 500 trained and experienced employees dedicated to the principles of innovative design, superior quality and continuing service.

At Kewaunee, our Associates recognize that our job is not complete until our customer is satisfied. Our project management concept includes the integration of manufacturing requirements, design/engineering and a construction schedule to assure on-time delivery and completion of installations that will provide excellent function and longevity.

History

In 1906, a handful of investors with a vision hired 18 workers and formed what is today the Kewaunee Scientific Corporation. Their goal was ambitious: build a superior line of furniture and accessories.

Until the early 1900's, America relied on Europe, and particularly Germany, for the bulk of its laboratory equipment. But after World War I the American scientific industry began to gain ground. At Kewaunee, we grew rapidly. We expanded our market with an elaborate dealer organization. By the end of the 1920's, we were building both steel and wood laboratory furniture and accessories.

During World War II, we were a government contractor for the Air Corps, and an important supplier for the Manhattan Project.

After the war, America experienced a technological explosion resulting in increased demand for scientific

laboratory equipment. Kewaunee responded by building its present facilities in Statesville, North Carolina and its staff of experienced people.

A lot has changed in 100 years but not the original goal: to build a superior line of furniture to meet the needs of all markets, the best that can be built.

Experience

Many years of experience have qualified Kewaunee as a leader in the design and manufacture of laboratory, technical, and laminate furniture. We serve clients from many disciplines in industry, research, education, government, and healthcare.

From original designs and layouts through complete installations, Kewaunee has the experience to make your facility the best that it can be.

Facilities

The Company's corporate headquarters are located in Statesville, North Carolina along with three manufacturing facilities producing laboratory, technical, and laminate furniture for the domestic and international markets. Laboratory furniture products include: both steel and wood cabinetry, fume hoods, adaptable modular systems, moveable workstations, environmentally friendly casework, biological safety cabinets, and epoxy resin counters and sinks. Technical furniture products include: column systems, slotted-post systems, pedestal systems, and stand-alone benches. Laminate furniture and architectural millwork includes: laminate casework, systems, and related products for educational, healthcare and industrial applications. Our manufacturing facility in Bangalore, India serves local and Asian markets. The Company also has subsidiaries in Singapore, China, and India.



Laminate Furniture & Architectural Millwork



SPEKTRUM Health Care



SPEKTRUM Education

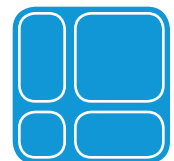

SPEKTRUM Laboratory

COLORS – PATTERNS – TEXTURES

Kewaunee
SPEKTRUM

Laminate Furniture and
Architectural Millwork

for Healthcare, Education, and Laboratories

- Legendary Kewaunee Quality
- Option Rich Offering
- Custom Designs
- Environmentally Friendly Options
- Made in the USA



SPEKTRUM Green



SPEKTRUM Value



Kewaunee Quality Construction

Contents:

- Introduction..... 1
- Construction Features 2
- Check Lists 4
- Base Cabinet Details..... 6
- Drawer Dimensions..... 7
- Aprons..... 8
- Base Cabinets
 - Open & Door Units 9
 - Drawer Units 17
 - Combination Units..... 25
 - Sink Units 30
- Wall Cabinet Details 33
- Wall Cabinets 34
- Tall Cabinet Details 44
- Tall Cabinets..... 45
- Work Tops 56
- Wall Shelving Assemblies 58
- Technical Information..... 60
- Index 62



Cabinet Face Styles

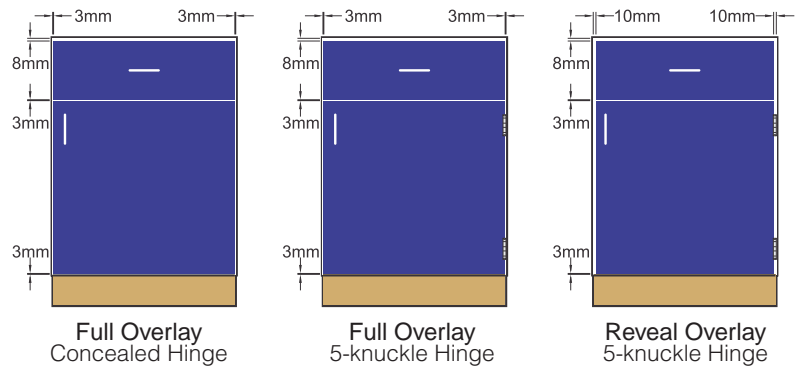

Drawer Slide Options



Full-extension ball bearing drawer slide



3/4-extension self-closing drawer slide

Kewaunee Quality Construction

SPEKTRUM LAMINATE FURNITURE

is engineered and fabricated to exacting specifications. From raw material to finished products, our quality assurance program is designed to certify that Kewaunee products exceed established industry standards.

CABINET FACE STYLES

- Reveal Overlay — 10mm reveals — 5-knuckle hinge only
- Full Overlay — 3mm reveals — 5-knuckle or concealed hinge

CHOICE OF CORE MATERIALS

Solid, 19mm (3/4") thick, top, bottom and end panels joined with multiple dowel and glue construction to provide complete case rigidity. Core material options include:

- Particleboard
- Plywood
- MDF
- FSC® Certified
- NAUF
- Moisture Resistant

COLOR OPTIONS

Spektrum cabinets are available in all the laminate offerings from Formica® and Wilsonart®. Most colors are available with matching edge banding. Standard interior colors are: White, Beige, and Grey.

MULTIPLE EDGE BANDING OPTIONS

Front exposed edges of cabinets are faced with PVC edge banding in one of four standard colors or to match cabinet body laminate. Edge banding is available in two thickness options:

- 1.0 millimeter banding
- 3.0 millimeter banding

FULL DEPTH SHELVES WITH BANDING OPTIONS

Solid 19mm (3/4") thick shelves, are surfaced on both sides by thermally fused melamine to match the cabinet interior. Fully adjustable on 32mm centers secured with corrosion-resistant, twin pin clips to prevent accidental shelf movement. Three banding options and two thickness options:

- banded front edge only
- banded front and back edge
- banded all four edges
- 1.0 millimeter banding
- 3.0 millimeter banding

DRAWER CONSTRUCTION

13mm (1/2") drawer sides, back, and inside front, joined with multiple dowel and glue construction. 13mm (1/2") bottom captured on all four sides. Drawer parts are surfaced on both sides by thermally fused melamine to match the cabinet interior.

DRAWER SUSPENSION

- 3/4-extension, epoxy-coated, self-closing drawer slide load rated at 100lbs.
- Full-extension, ball bearing drawer slide load rated at 100lbs.
- Full-extension, ball bearing drawer slide load rated at 150lbs. (150lb, full-extension slides used on all file drawers and paper storage drawers)

DOOR HINGES

- Institutional-type, five-knuckle, offset, steel hinge, offered in five finishes, load rated at 150lbs.
- Concealed, self-closing 110° swing
- Concealed, self-closing 165° swing

DRAWER & DOOR PULLS

- D-shaped 8mm diameter wire pull available in seven standard finishes

OTHER HARDWARE OPTIONS

- Disc tumbler locks
- Pin tumbler locks
- Label holders

Hardware Options

5-Knuckle Hinge

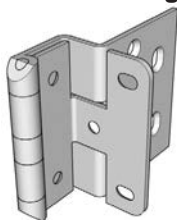

Available Finishes:
 Chrome Coat
 Stainless Steel
 White Beige
 Grey Black

Concealed Hinge Self-closing

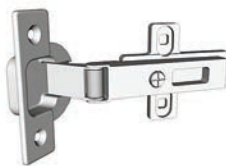

Available Swing Opening:
 110° Swing
 165° Swing

D-shaped Wire Pull



Available Finishes:
 Brushed Chrome
 Stainless Steel
 Chrome Coat
 White Beige
 Grey Black

Bid Request Form – Cabinet Options

Cabinet Core Material

Cabinet Core <i>select one</i>	Doors & Drawers <i>select one</i>	Cabinet Shelves <i>select one</i>	
<input checked="" type="checkbox"/> std	<input checked="" type="checkbox"/> std	<input checked="" type="checkbox"/> std	Particleboard
<input type="checkbox"/>	<input type="checkbox"/>	<input type="checkbox"/>	Plywood
<input type="checkbox"/>	<input type="checkbox"/>	<input type="checkbox"/>	MDF

select all required

<input type="checkbox"/> FSC	<input type="checkbox"/> AWI Certified
<input type="checkbox"/> NAUF	<input type="checkbox"/> Economy
<input type="checkbox"/> Other _____	<input type="checkbox"/> Custom
	<input type="checkbox"/> Premium

Laminates *(Wilsonart standard finishes are 38 and 60)*

Exterior Color 1 _____
(example WA-7909-60 Fusion Maple)

Exterior Color 2 _____
(if required)

Interior Color of Solid Door Cabinets

White Beige Grey Match Exterior

Interior Color of Open & Glass Door Cabinets

Match Exterior Match Interior

Edgebanding

Cabinet Body Edgebanding *select one*

std 1mm PVC 3mm PVC Self Edge

Cabinet Body Edgebanding Color *select one*

std Match Exterior other _____

Doors & Drawer Head Edgebanding *select one*

1mm PVC std 3mm PVC Self Edge

Doors & Drawer Head Edgebanding Color *select one*

std Match Exterior other _____

Cabinet Shelf Edgebanding *select one*

std 1mm PVC 3mm PVC Self Edge

Cabinet Shelf Edges to Band *select one*

std front edge only front & back edge all four edges other _____

notes: _____

Hinges *select one Hinge Type only (Concealed, 5-Knuckle, or Other)*

std Concealed – Self Closing

select swing opening

std 110° Swing
 165° Swing

5-Knuckle

select Finish, Overlay, and Catch

Chrome Coat
 Stainless Steel
 Black

Door Overlay

Reveal Overlay *(unnotched)*
 Full Overlay *(door notched)*

Door Catch

std Magnetic

Other _____

Drawer & Door Pulls *select one*

D-shaped Wire Pull

8mm dia. – 96mm centers

std Brushed Chrome
 Stainless Steel
 White
 Black
 Other _____

Door & Drawer Locks

select one

No locks
 As shown on drawings
 All Cupboards & Drawers

Keying Arrangement

select one

All Keyed Alike
no Security Panels
 Keyed Alike / Room
no Security Panels
 All Keyed Different
includes Security Panels
 Keyed / Schedule
Security Panels / Schedule

Lock Type

select one

std Disk Locks
 Pin Locks

Drawer Suspension

Standard Drawers

select one

std 100 lb load rated – 3/4-extension
 100 lb load rated – full-extension
 150 lb load rated – full-extension
 Other _____

File Drawers

select one

Glass *select one*

std 1/8" Float Glass
 1/8" Tempered Glass
 1/4" Safety Glass

Glass Retainer *select one*

White Plastic Retainer
 Beige Plastic Retainer
 Grey Plastic Retainer

Shelf Clip *select one*

std 2 Pin Clear Polycarbonate
 other _____

Bid Request Form – Work Tops & Shelving

Core Material

Work Top Core <i>select one</i> <input checked="" type="checkbox"/> std <input type="checkbox"/> <input type="checkbox"/>	Shelving Core <i>select one</i> <input checked="" type="checkbox"/> std <input type="checkbox"/> <input type="checkbox"/>	Particleboard Plywood MDF
--	--	---------------------------------

select all required

<input type="checkbox"/> Moisture Resistant	<input type="checkbox"/> AWI Certified
<input type="checkbox"/> FSC	<input type="checkbox"/> Economy
<input type="checkbox"/> NAUF	<input type="checkbox"/> Custom
<input type="checkbox"/> Other _____	<input type="checkbox"/> Premium

Note: Moisture Resistant Standard at all Sink Areas

Work Top Front Edge

1" Thick Work Top Core <input type="checkbox"/> 3mm PVC Edge Band <input type="checkbox"/> Self-edged <input type="checkbox"/> Premium Self-edged <input type="checkbox"/> Waterfall <input type="checkbox"/> Full Round	1½" Thick Work Top Core <input type="checkbox"/> Self-edged <input type="checkbox"/> Premium Self-edged <input type="checkbox"/> Other _____ _____ _____
---	--

Laminates (Wilsonart standard finishes are 38 and 60)

Work Tops Standard Grade Chemical Resistant

color/finish _____
(example WA-7909-60 Fusion Maple)

PVC Edge Banding Color
(select only if selecting 3mm Front Edge Banding)
 Match Work Top
 Other _____

Shelving Standard Grade Chemical Resistant

color/finish _____

Curbs

No Curbs
 4" High Applied Curbs

other

Curb Thickness
 3/4" Thick Curbs
 1" Thick Curbs

Top Edge
 3mm PVC Edge Band
 Self-edged

Shelving

3/4" Thick Core
 1" Thick Core

other

Edge Banding
 Self-edged
 3mm PVC Edge Band
 Match Shelf Color

other

Edges Banded
 All Four Edges

other

Work Tops Notes

Shelving Notes

Specification Notes

Cabinet & Drawer Dimensions

Sample Catalog Entry

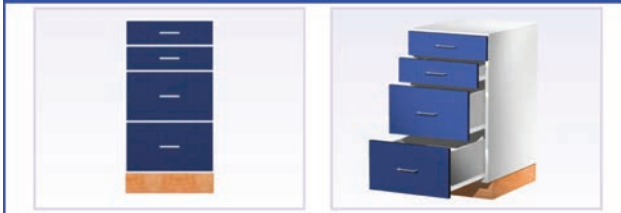

D4106

H	D	W
30"	14"	12"
32.5"	18"	15"
35"	24"	18"
	29"	21"
		24"
		27"
		30"
		33"
		36"

Base cabinet with one stack of four drawers. The top two drawers are always 4u high, with three larger drawers below.

Drawer Heights (units): 4,4,6,6 (30"H), 4,4,7,7 (32.5"H), 4,4,8,8 (35"H).

- available Cabinet Widths
- available Cabinet Depths
- available Cabinet Heights

(30" = Sitting Height 32.5" = ADA Height 35" = Standing Height)

Drawer Sizes

Drawer sizes are based on a 32mm design which provides a maximum amount of flexibility while also ensuring that adjacent cabinets can have drawers that are the same height.

For this reason, drawer heights are referred to in "units". The smallest drawers are 4 units high, while large file drawers are 10 units high.

The example below explains how these sizes are communicated throughout the catalog.

EXAMPLE:

The **30" high cabinet** has two drawers 4 units high and two drawers 6 units high.

The **32.5" high cabinet** has two drawers 4 units high and two drawers 7 units high.

The **35" high cabinet** has two drawers 4 units high and two drawers 8 units high.

Drawer Dimensions

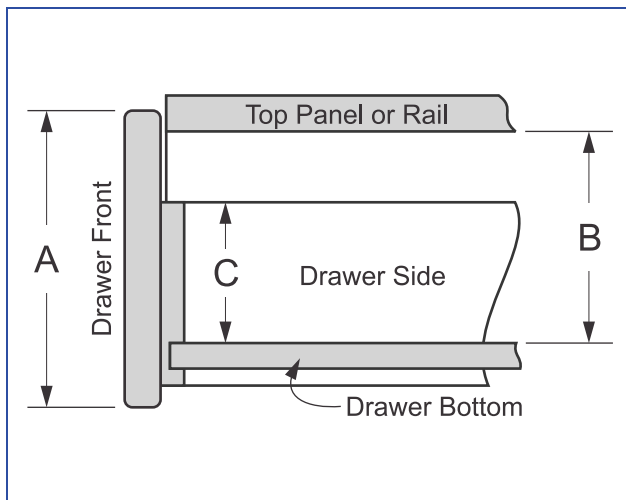

Drawer Unit Height	Drawer Height Dimension					
	Drawer Front Height (A)		Drawer Space Usable Height (B)		Drawer Box Inside Height (C)	
	mm	inches	mm	inches	mm	inches
4	125	4.92	81	3.19	42	1.65
5	157	6.18	113	4.44	74	2.91
6	189	7.44	145	5.71	106	4.17
7	221	8.70	177	6.97	138	5.43
8	253	9.96	209	8.23	170	6.69
9	285	11.22	241	9.49	202	7.95
10	317	12.48	273	10.75	234	9.21

Base Cabinet Construction Detail

13mm Back Panel
fully captured by top, bottom,
and end panels

19mm Full Cabinet Top
doweled to both end panels

19mm Wall Nailer
doweled to both
end panels.

Multiple Drawer Slide Options
100 lb load rated, 3/4-extension
100 lb load rated, full-extension
150 lb load rated, full-extension

13mm Drawer Box
with fully captured bottom.
Drawer front and back
fastened to sides with 8mm
hardwood fluted dowels.

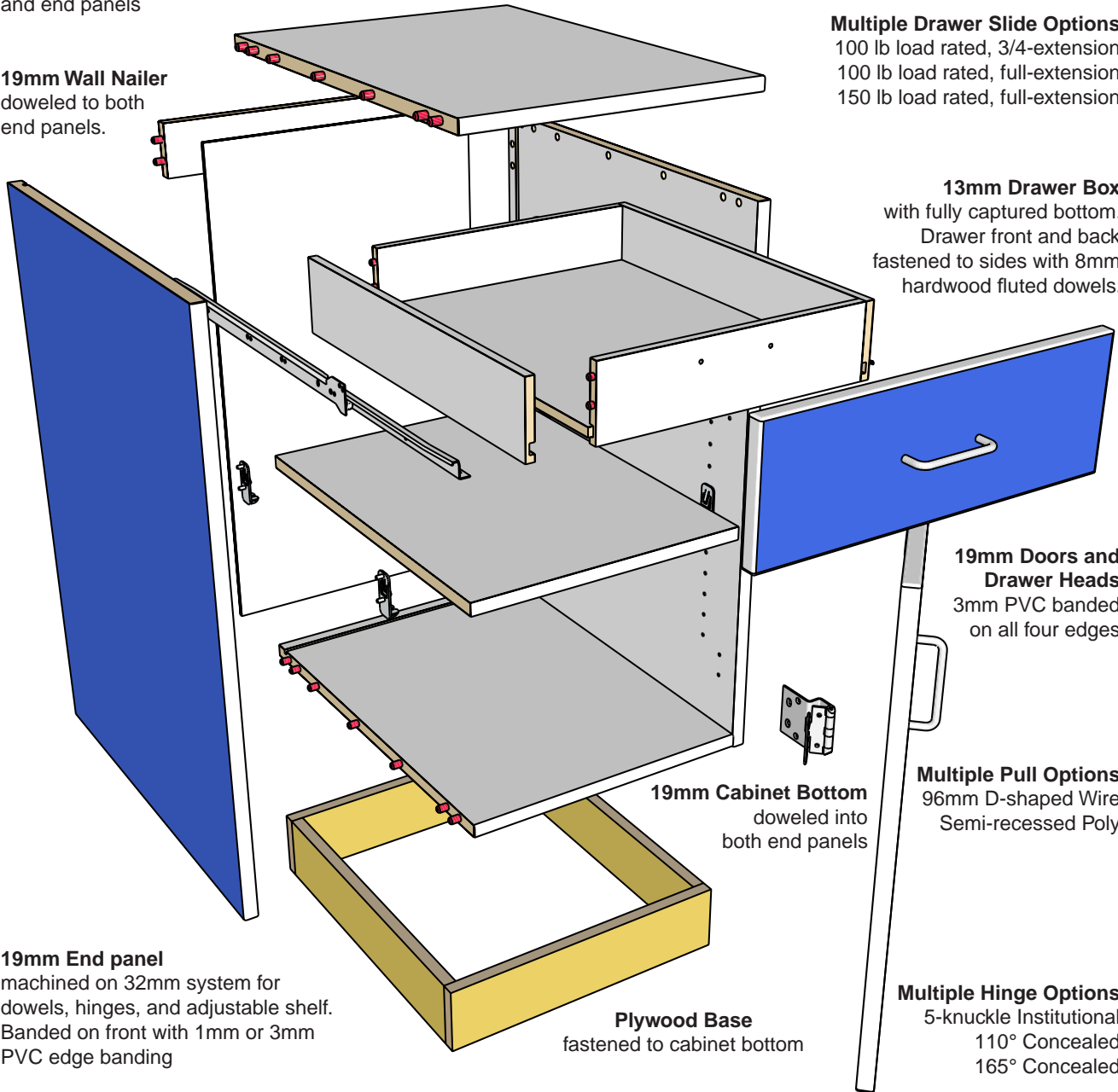

E2101 Drawer/Cupboard Base Cabinet

Aprons



A1100

H	D	W
5"	14"	15"
	18"	18"
	24"	21"
	29"	24"
		27"
		30"

Single drawer assembly with one 4u high drawer.

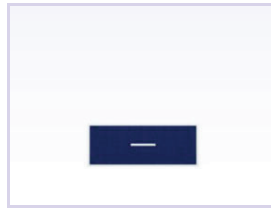

A1102

H	D	W
6"	14"	15"
	18"	18"
	24"	21"
	29"	24"
		27"
		30"

Single drawer assembly with one 5u high drawer.



A1200

H	D	W
5"	14"	30"
	18"	36"
	24"	42"
	29"	48"

Double drawer assembly with two 4u high drawers.



A1202

H	D	W
6"	14"	30"
	18"	36"
	24"	42"
	29"	48"

Double knee drawer assembly with one row of two 6" high drawers.



A5000

H	D	W
5"		24"
6"		27"
		30"
		33"
		36"
		39"
		42"
		45"
		48"

Apron rail.

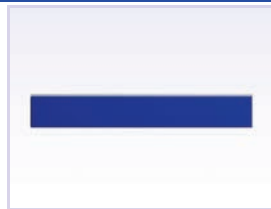

A5002

H	D	W
5"		24"
6"		27"
		30"
		33"
		36"
		39"
		42"
		45"
		48"

Apron rail with applied false front.

Base Cabinets - Open and Door Units

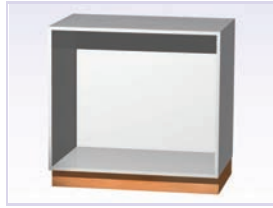

C0000

H	D	W	Open base cabinet.
30"	13"	12"	
32.5"	17"	15"	
35"	23"	18"	
	28"	21"	
		24"	
		27"	
		30"	
		33"	
		36"	

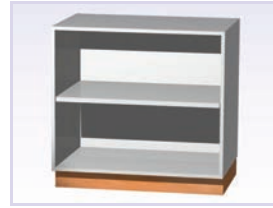

C0002

H	D	W	Open base cabinet with one adjustable shelf.
30"	13"	12"	
32.5"	17"	15"	
35"	23"	18"	
	28"	21"	
		24"	
		27"	
		30"	
		33"	
		36"	



C0004

H	D	W	Open base cabinet with one fixed shelf.
30"	13"	12"	
32.5"	17"	15"	
35"	23"	18"	
	28"	21"	
		24"	
		27"	
		30"	
		33"	
		36"	



C0006

H	D	W	Double sided pass-through open base cabinet with one adjustable shelf.
30"	13"	12"	
32.5"	17"	15"	
35"	23"	18"	
	28"	21"	
		24"	
		27"	
		30"	
		33"	
		36"	

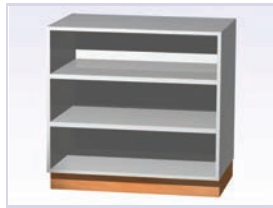

C0008

H	D	W	Open base cabinet with two fixed shelves.
30"	13"	12"	
32.5"	17"	15"	
35"	23"	18"	
	28"	21"	
		24"	
		27"	
		30"	
		33"	
		36"	



C0010

H	D	W	Open base cabinet with one vertical division and one row of adjustable shelves, creating four compartments.
30"	13"	24"	
32.5"	17"	27"	
35"	23"	30"	
	28"	33"	
		36"	
		39"	
		42"	
		45"	
		48"	

Base Cabinets - Open and Door Units



C0012

H	D	W
30"	13"	24"
32.5"	17"	27"
35"	23"	30"
	28"	33"
		36"
		39"
		42"
		45"
		48"

Open base cabinet with one vertical division and one row of fixed shelves, creating four compartments.

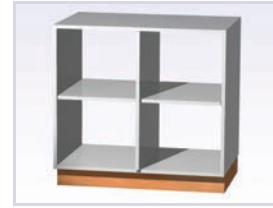

C0014

H	D	W
30"	13"	24"
32.5"	17"	27"
35"	23"	30"
	28"	33"
		36"
		39"
		42"
		45"
		48"

Double sided pass-through open base cabinet with one vertical division and one row of adjustable shelves, creating four compartments.



C0016

H	D	W
30"	13"	12"
32.5"	17"	15"
35"	23"	18"
	28"	21"
		24"
		27"
		30"
		33"
		36"

Open base cabinet with one fixed shelf located 9" from the top, and one adjustable shelf below.



C0018

H	D	W
30"	13"	30"
32.5"	17"	33"
35"	23"	36"
	28"	39"
		42"
		45"
		48"

Open base cabinet with two vertical divisions and one row of adjustable shelves, creating six compartments.



C0020

H	D	W
30"	13"	30"
32.5"	17"	33"
35"	23"	36"
	28"	39"
		42"
		45"
		48"

Open base cabinet with two vertical divisions and one row of fixed shelves, creating six compartments.



C0022

H	D	W
30"	13"	24"
32.5"	17"	27"
35"	23"	30"
	28"	33"
		36"
		39"
		42"
		45"
		48"

Open base cabinet with one vertical division and two rows of fixed shelves, creating six compartments.

Base Cabinets - Open and Door Units



C0024

H	D	W
30"	13"	30"
32.5"	17"	33"
35"	23"	36"
	28"	39"
		42"
		45"
		48"

Open base cabinet with two vertical divisions and two rows of fixed shelves, creating nine compartments.



C0026

H	D	W
30"	13"	36"
32.5"	17"	39"
35"	23"	42"
	28"	45"
		48"

Open base cabinet with three vertical divisions and one row of adjustable shelves, creating eight compartments.



C0028

H	D	W
30"	13"	36"
32.5"	17"	39"
35"	23"	42"
	28"	45"
		48"

Open base cabinet with three vertical divisions and one row of fixed shelves, creating eight compartments.



C0030

H	D	W
30"	13"	36"
32.5"	17"	39"
35"	23"	42"
	28"	45"
		48"

Open base cabinet with three vertical divisions and two rows of fixed shelves, creating twelve compartments.



C0800

H	D	W
30"	36"	36"
32.5"		
35"		

Open diagonal corner base cabinet with one fixed shelf.

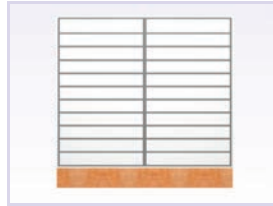

C0900

H	D	W
30"	13"	24"
32.5"	17"	27"
35"	23"	30"
	28"	33"
		36"

Open folio cabinet with one vertical division and multiple 1/4" adjustable horizontal dividers providing 2-1/4" tall compartments.

Base Cabinets - Open and Door Units

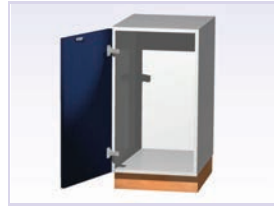

C1100

H	D	W	Single door base cabinet. (Left hinged)
30"	14"	12"	
32.5"	18"	15"	
35"	24"	18"	
	29"	21"	
		24"	

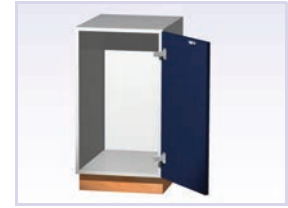
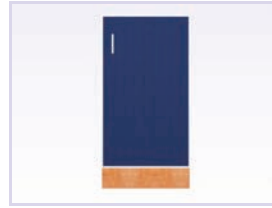

C1101

H	D	W	Single door base cabinet. (Right hinged)
30"	14"	12"	
32.5"	18"	15"	
35"	24"	18"	
	29"	21"	
		24"	



C1102

H	D	W	Single door base cabinet without a base, open at the bottom. (Left hinged)
30"	14"	12"	
32.5"	18"	15"	
35"	24"	18"	
	29"	21"	
		24"	



C1103

H	D	W	Single door base cabinet without a base, open at the bottom. (Right hinged)
30"	14"	12"	
32.5"	18"	15"	
35"	24"	18"	
	29"	21"	
		24"	



C1104

H	D	W	Single door base cabinet with one adjustable shelf. (Left hinged)
30"	14"	12"	
32.5"	18"	15"	
35"	24"	18"	
	29"	21"	
		24"	



C1105

H	D	W	Single door base cabinet with one adjustable shelf. (Right hinged)
30"	14"	12"	
32.5"	18"	15"	
35"	24"	18"	
	29"	21"	
		24"	

Base Cabinets - Open and Door Units

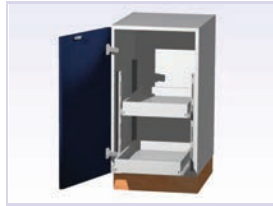
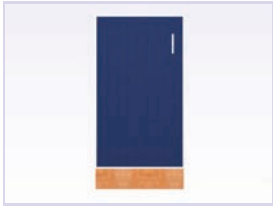

C1106

H	D	W	
30"	14"	12"	Single door base cabinet with two pull-out trays. (Left hinged)
32.5"	18"	15"	
35"	24"	18"	
	29"	21"	
		24"	

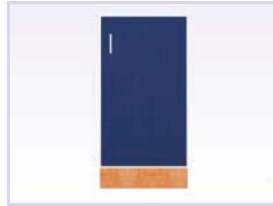

C1107

H	D	W	
30"	14"	12"	Single door base cabinet with two pull-out trays. (Right hinged)
32.5"	18"	15"	
35"	24"	18"	
	29"	21"	
		24"	

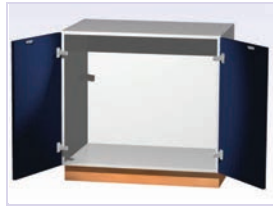

C1200

H	D	W	
30"	14"	24"	Double door base cabinet.
32.5"	18"	27"	
35"	24"	30"	
	29"	33"	
		36"	



C1202

H	D	W	
30"	14"	24"	Double door base cabinet without a base, open at the bottom.
32.5"	18"	27"	
35"	24"	30"	
	29"	33"	
		36"	

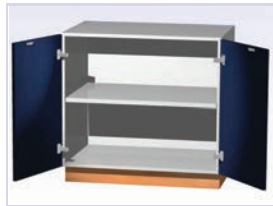

C1204

H	D	W	
30"	14"	24"	Double door base cabinet with one adjustable shelf.
32.5"	18"	27"	
35"	24"	30"	
	29"	33"	
		36"	

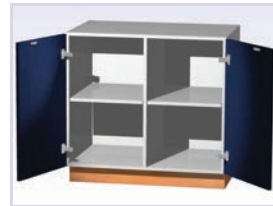

C1206

H	D	W	
30"	14"	24"	Double door base cabinet with one vertical division and one row of adjustable shelves, creating four compartments.
32.5"	18"	27"	
35"	24"	30"	
	29"	33"	
		36"	
		39"	
		42"	
		45"	
		48"	

Base Cabinets - Open and Door Units

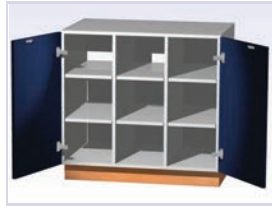

C1208

H	D	W
30"	14"	30"
32.5"	18"	33"
35"	24"	36"
	29"	39"
		42"
		45"
		48"

Double door base cabinet with two vertical divisions and two rows of adjustable shelves, creating nine compartments.

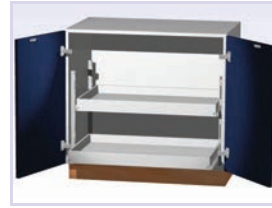

C1210

H	D	W
30"	14"	24"
32.5"	18"	27"
35"	24"	30"
	29"	33"
		36"

Double door base cabinet with two adjustable pull-out trays.



C1212

H	D	W
30"	24"	25"
32.5"		
35"		

Double door base cabinet with one vertical division and type (TBD-#1) tote trays.

30" = 10 trays, 32.5" = 12 trays; 35" = 14 trays

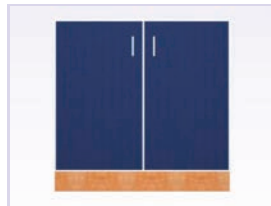

C1214

H	D	W
30"	24"	36"
32.5"		
35"		

Double door base cabinet with two vertical divisions and type (TBD-#1) tote trays.

30" = 15 trays, 32.5" = 18 trays; 35" = 21 trays



C1216

H	D	W
30"	24"	48"
32.5"		
35"		

Double door base cabinet with three vertical divisions and type (TBD-#1) tote trays.

30" = 20 trays, 32.5" = 24 trays; 35" = 28 trays

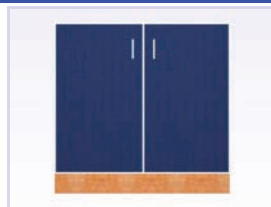

C1218

H	D	W
30"	24"	48"
32.5"		
35"		

Double door base cabinet with two vertical divisions and type (TBD-#2) tote trays.

30" = 15 trays, 32.5" = 18 trays; 35" = 21 trays

Base Cabinets - Open and Door Units



C1220

H	D	W
30"	14"	24"
32.5"	18"	27"
35"	24"	30"
	29"	33"
		36"
		39"
		42"
		45"
		48"

Double door folio cabinet with one vertical division and 1/4" adjustable horizontal dividers spaced equally to provide 2-1/4" high compartments.

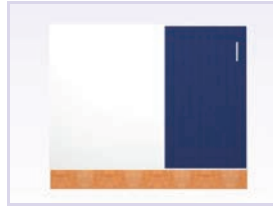

C1800

H	D	W
30"	14"	42"
32.5"	18"	45"
35"	24"	48"
	29"	

Blind corner cabinet with one fixed shelf. (Left hinged)

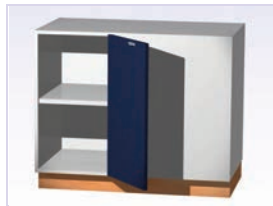

C1801

H	D	W
30"	14"	42"
32.5"	18"	45"
35"	24"	48"
	29"	

Blind corner cabinet with one fixed shelf. (Right hinged)

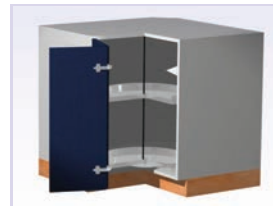
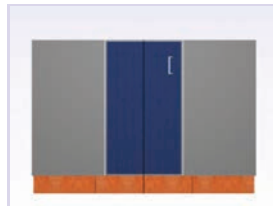

C1802

H	D	W
30"	36"	36"
32.5"		
35"		

Pie-cut corner cabinet with two revolving polymer shelves. (Left hinged)



C1803

H	D	W
30"	36"	36"
32.5"		
35"		

Pie-cut corner cabinet with two revolving polymer shelves. (Right hinged)

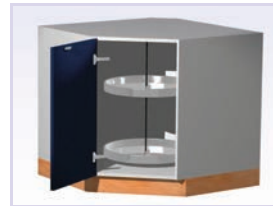
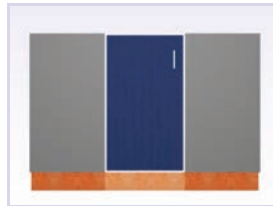

C1804

H	D	W
30"	36"	36"
32.5"		
35"		

Diagonal corner cabinet with two revolving polymer shelves. (Left hinged)

Base Cabinets - Open and Door Units

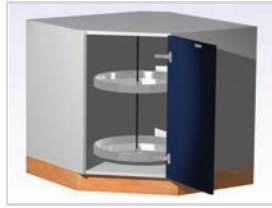

C1805

H	D	W
30"	36"	36"
32.5"		
35"		

Diagonal corner cabinet with two revolving polymer shelves. (Right hinged)

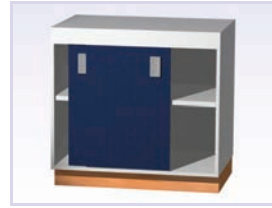

C3200

H	D	W
30"	13"	24"
32.5"	17"	27"
35"	23"	30"
	28"	33"
		36"

Sliding door base cabinet with one adjustable shelf.

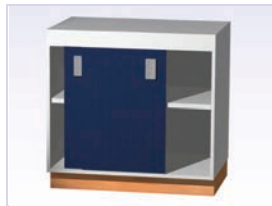

C3202

H	D	W
30"	13"	24"
32.5"	17"	27"
35"	23"	30"
	28"	33"
		36"
		39"
		42"
		45"
		48"

Sliding door base cabinet with one vertical division and one row of adjustable shelves, creating four compartments.

Base Cabinets - Drawer Units



D1104

H	D	W	Base cabinet with one full-size drawer.
30"	18"	18"	
32.5"	24"	21"	
35"		24"	

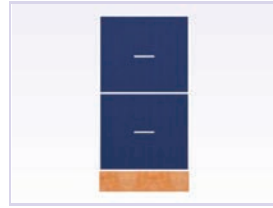

D2100

H	D	W	Base cabinet with one stack of two equal drawers.
30"	14"	12"	
32.5"	18"	15"	
35"	24"	18"	
	29"	21"	
		24"	
		27"	
		30"	
		33"	
		36"	

Drawer Heights (units): 10,10 (30"H), 11,11 (32.5"H), 12,12 (35"H).



D2102

H	D	W	Two drawer base cabinet with the top drawer always 5u high.
30"	14"	12"	
32.5"	18"	15"	
35"	24"	18"	
	29"	21"	
		24"	
		27"	
		30"	
		33"	
		36"	

Drawer Heights (units): 5,15 (30"H), 5,17 (32.5"H), 5,19 (35"H).



D2104

H	D	W	Two drawer file cabinet with 150 lb slides.
30"	14"	16"	
	18"	19"	
	24"		
	29"		

Drawer Heights (units): 10F,10F (30"H).



D2106

H	D	W	Two drawer base cabinet with one file drawer on bottom. File drawer has 150 lb slides.
30"	14"	16"	
32.5"	18"	19"	
35"	24"		
	29"		

Drawer Heights (units): 10,10F (30"H), 12,10F (32.5"H), 14,10F (35"H).



D2108

H	D	W	Two drawer lateral file cabinet designed to accommodate legal and letter size files. File drawers have 150 lb slides.
30"	24"	18"	
	29"	21"	
		24"	
		27"	
		30"	
		33"	
		36"	

Drawer Heights (units): 10F,10F (30"H).

Base Cabinets - Drawer Units



D2200

H	D	W
30"	14"	24"
32.5"	18"	27"
35"	24"	30"
	29"	33"
		36"
		39"
		42"
		45"
		48"

Four drawer base cabinet with two stacks of two drawers. All drawers are the same size.

Drawer Heights (units): 10, 10 (30"H), 11, 11 (32.5"H), 12, 12 (35"H).

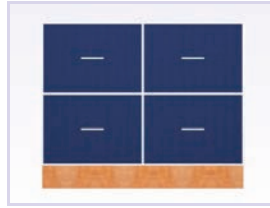

D2202

H	D	W
30"	14"	31"
	18"	37"
	24"	
	29"	

Four drawer file cabinet with two stacks of two drawers. All drawers are the same size and have 150 lb slides.

Drawer Heights (units): 10F, 10F (30"H).



D2204

H	D	W
30"	24"	36"
	29"	39"
		42"
		45"
		48"

Four drawer lateral file cabinet with two stacks of two drawers. All drawers are the same size and accommodate legal and letter size files. File drawers have 150 lb slides.

Drawer Heights (units): 10F, 10F (30"H).

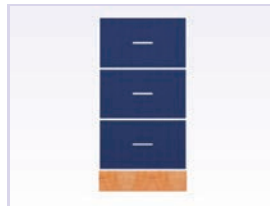

D3100

H	D	W
30"	14"	12"
32.5"	18"	15"
35"	24"	18"
	29"	21"
		24"
		27"
		30"
		33"
		36"

Base cabinet with one stack of three drawers.

Drawer Heights (units): 6, 7, 7 (30"H), 7, 7, 8 (32.5"H), 8, 8, 8 (35"H).



D3102

H	D	W
30"	14"	12"
32.5"	18"	15"
35"	24"	18"
	29"	21"
		24"
		27"
		30"
		33"
		36"

Base cabinet with one stack of three drawers. The bottom drawer is always 10u high, and the two above are equally sized.

Drawer Heights (units): 5, 5, 10 (30"H), 6, 6, 10 (32.5"H), 7, 7, 10 (35"H).

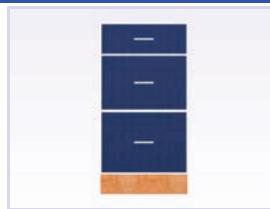

D3104

H	D	W
30"	14"	12"
32.5"	18"	15"
35"	24"	18"
	29"	21"
		24"
		27"
		30"
		33"
		36"

Base cabinet with one stack of three drawers. The top drawer is always 5u high, and the bottom drawer is always 10u high.

Drawer Heights (units): 5, 5, 10 (30"H), 5, 7, 10 (32.5"H), 5, 9, 10 (35"H).

Base Cabinets - Drawer Units



D3106

H	D	W
30"	14"	12"
32.5"	18"	15"
35"	24"	18"
	29"	21"
		24"
		27"
		30"
		33"
		36"

Three drawer base cabinet with a pullboard. The top drawer plus the pull board dimension is always 5u high.

Drawer Heights (units): 4,5,10 (30"H), 4,7,10 (32.5"H), 4,9,10 (35"H).



D3108

H	D	W
43"	14"	16"
	18"	19"
	24"	
	29"	

Three drawer file cabinet with 150 lb slides.

Drawer Heights (units): 10F,10F,10F (43"H).



D3110

H	D	W
35"	14"	16"
	18"	19"
	24"	
	29"	

Base cabinet with one stack of three drawers. The top drawer is always 4u high, with two file drawers located below. File drawers have 150 lb slides.

Drawer Heights (units): 4,10F,10F (35"H).



D3112

H	D	W
43"	24"	18"
	29"	21"
		24"
		27"
		30"
		33"
		36"

Three drawer lateral file cabinet. All drawers are the same size and accommodate legal and letter size files. File drawer has 150 lb slides.

Drawer Heights (units): 10F,10F,10F (43"H).



D3114

H	D	W
35"	24"	18"
	29"	21"
		24"
		27"
		30"
		33"
		36"

Base cabinet with three drawers. The top drawer is always 4u high. The two lateral file drawers below accommodate legal and letter size files. File drawer has 150 lb slides.

Drawer Heights (units): 4,10F,10F (35"H).

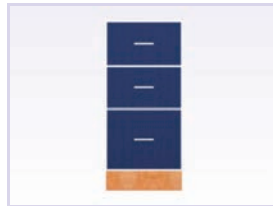

D3116

H	D	W
30"	14"	16"
32.5"	18"	19"
35"	24"	
	29"	

Three drawer base cabinet with one file drawer at the bottom and two equal drawers at the top. File drawer has 150 lb slides.

Drawer Heights (units): 5,5,10F (30"H), 6,6,10F (32.5"H), 7,7,10F (35"H).

Base Cabinets - Drawer Units

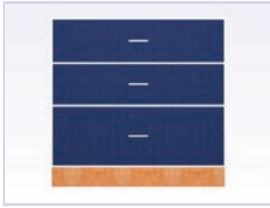

D3118

H	D	W
30"	24"	18"
32.5"	29"	21"
35"		24"
		27"
		30"
		33"
		36"

Three drawer base cabinet with two equal drawers at the top and one lateral file drawer at the bottom that adjusts to accommodate legal or letter size files. File drawer has 150 lb slides.

Drawer Heights (units): 5,5,10F (30"H), 6,6,10F (32.5"H), 7,7,10F (35"H).



D3200

H	D	W
30"	14"	24"
32.5"	18"	27"
35"	24"	30"
	29"	33"
		36"
		39"
		42"
		45"
		48"

Six drawer base cabinet with two stacks of three drawers.

Drawer Heights (units): 6,7,7 (30"H), 7,7,8 (32.5"H), 8,8,8 (35"H).



D3202

H	D	W
30"	14"	24"
32.5"	18"	27"
35"	24"	30"
	29"	33"
		36"
		39"
		42"
		45"
		48"

Six drawer base cabinet with two stacks of three drawers. The top drawer row is always 5u high.

Drawer Heights (units): 5,7,8 (30"H), 5,8,9 (32.5"H), 5,9,10 (35"H).



D3204

H	D	W
30"	14"	24"
32.5"	18"	27"
35"	24"	30"
	29"	33"
		36"

Four drawer base cabinet with two split drawers across the top and two full width drawers at the bottom.

Drawer Heights (units): 6,7,7 (30"H), 7,7,8 (32.5"H), 8,8,8 (35"H).



D3206

H	D	W
35"	24"	31"
	29"	37"

Six drawer base cabinet with two stacks of three drawers. The top drawer row is always 4u high. Located below are four file drawers that have 150 lb slides.

Drawer Heights (units): 4,10F,10F (35"H).

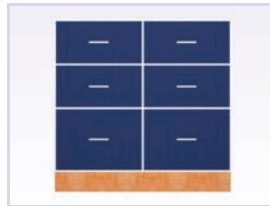

D3208

H	D	W
30"	14"	31"
32.5"	18"	37"
35"	24"	
	29"	

Six drawer base cabinet with two stacks of three drawers. Two file drawers are along the bottom, and two rows of equal size drawers are above. File drawers have 150 lb slides.

Drawer Heights (units): 5,5,10F (30"H), 6,6,10F (32.5"H), 7,7,10F (35"H).

Base Cabinets - Drawer Units



D4100

H	D	W
30"	14"	12"
32.5"	18"	15"
35"	24"	18"
	29"	21"
		24"
		27"
		30"
		33"
		36"

Base cabinet with one stack of four drawers.

Drawer Heights (units): 5,5,5,5 (30"H), 5,5,6,6 (32.5"H), 6,6,6,6 (35"H).

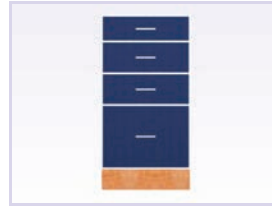

D4102

H	D	W
32.5"	14"	12"
35"	18"	15"
	24"	18"
	29"	21"
		24"
		27"
		30"
		33"
		36"

Base cabinet with one stack of four drawers. The bottom drawer is always 10u high, with three smaller drawers above.

Drawer Heights (units): 4,4,4,10 (32.5"H), 4,5,5,10 (35"H).



D4104

H	D	W
35"	14"	12"
	18"	15"
	24"	18"
	29"	21"
		24"
		27"
		30"
		33"
		36"

Base cabinet with one stack of four drawers. The top drawer is always 5u high, with three larger drawers below.

Drawer Heights (units): 5,6,6,7 (35"H).



D4106

H	D	W
30"	14"	12"
32.5"	18"	15"
35"	24"	18"
	29"	21"
		24"
		27"
		30"
		33"
		36"

Base cabinet with one stack of four drawers. The top two drawers are always 4u high, with three larger drawers below.

Drawer Heights (units): 4,4,6,6 (30"H), 4,4,7,7 (32.5"H), 4,4,8,8 (35"H).



D4108

H	D	W
30"	14"	12"
32.5"	18"	15"
35"	24"	18"
	29"	21"
		24"
		27"
		30"
		33"
		36"

Base cabinet with a pullboard and one stack of four drawers. The top drawer plus the pull board dimension is always 5u high.

Drawer Heights (units): 4,5,5,5 (30"H), 4,5,6,6 (32.5"H), 4,6,6,7 (35"H).

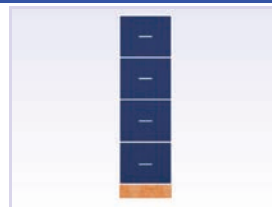

D4110

H	D	W
56"	14"	16"
	18"	19"
	24"	
	29"	

Four drawer file cabinet with 150 lb slides.

Drawer Heights (units): 10F, 10F, 10F, 10F (56"H).

Base Cabinets - Drawer Units

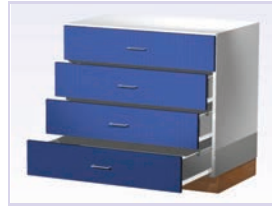

D4112

H	D	W
30"	24"	30"
32.5"	29"	33"
35"	35"	36"
		39"
		42"
		45"
		48"

Four drawer paper storage cabinet with 150 lb slides.

Drawer Heights (units): 5,5,5,5 (30"H), 5,5,6,6 (32.5"H), 6,6,6,6 (35"H).



D4114

H	D	W
33"	14"	16"
35"	18"	19"
	24"	
	29"	

Base cabinet with one stack of four drawers. One file drawer at the bottom and three smaller drawers above. File drawer has 150 lb slides.

Drawer Heights (units): 4,4,4,10F (32.5"H), 4,5,5,10F (35"H).



D4116

H	D	W
33"	24"	18"
35"	29"	21"
		24"
		27"
		30"
		33"
		36"

Base cabinet with one stack of four drawers. One lateral file drawer at the bottom and three smaller drawers above. File drawer has 150 lb slides.

Drawer Heights (units): 4,4,4,10F (32.5"H), 4,5,5,10F (35"H).



D4118

H	D	W
35"	14"	16"
	18"	19"
	24"	
	29"	

Base cabinet with a pullboard and one stack of four drawers. The top drawer plus the pull board dimension is always 5u high. At the bottom is one file drawer that has 150 lb slides.

Drawer Heights (units): 4,4,5,10F (35"H).

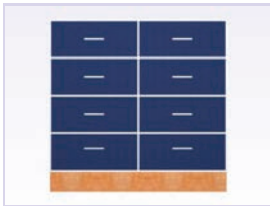

D4200

H	D	W
30"	14"	24"
32.5"	18"	27"
35"	24"	30"
	29"	33"
		36"
		39"
		42"
		45"
		48"

Eight drawer base cabinet with two stacks of four drawers.

Drawer Heights (units): 5,5,5,5 (30"H), 5,5,6,6 (32.5"H), 6,6,6,6 (35"H).



D4202

H	D	W
35"	14"	24"
	18"	27"
	24"	30"
	29"	33"
		36"
		39"
		42"
		45"
		48"

Eight drawer base cabinet with two stacks of four drawers. The top two rows of drawers are 5u high, and the bottom two rows are 7u high.

Drawer Heights (units): 5,5,7,7 (35"H).

Base Cabinets - Drawer Units



D4204

H	D	W
30"	14"	24"
32.5"	18"	27"
35"	24"	30"
	29"	33"
		36"

Base cabinet with four rows of drawers. The top row has two 5u high drawers. Below are three full width drawers.

Drawer Heights (units): 5,5,5,5 (30"H), 5,5,6,6 (32.5"H), 5,6,6,7 (35"H).

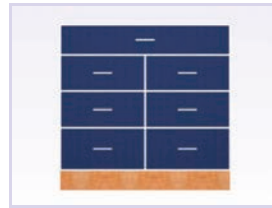

D4206

H	D	W
30"	14"	24"
32.5"	18"	27"
35"	24"	30"
	29"	33"
		36"

Base cabinet with four rows of drawers. The top row has one full width 5u high drawer. Below are two stacks of three drawers.

Drawer Heights (units): 5,5,5,5 (30"H), 5,5,6,6 (32.5"H), 5,6,6,7 (35"H).



D5100

H	D	W
30"	14"	12"
32.5"	18"	15"
35"	24"	18"
	29"	21"
		24"
		27"
		30"
		33"
		36"

Five drawer base cabinet.

Drawer Heights (units): 4,4,4,4,4 (30"H), 4,4,4,5,5 (32.5"H), 4,5,5,5,5 (35"H).



D5102

H	D	W
32.5"	14"	12"
35"	18"	15"
	24"	18"
	29"	21"
		24"
		27"
		30"
		33"
		36"

Five drawer base cabinet with the top drawer always 5u high.

Drawer Heights (units): 5,5,4,4,4 (32.5"H), 5,5,5,5,4 (35"H).



D5104

H	D	W
32.5"	14"	12"
35"	18"	15"
	24"	18"
	29"	21"
		24"
		27"
		30"
		33"
		36"

Five drawer base cabinet with a pull board at the top. The top drawer plus the pull board dimension is always 5u high.

Drawer Heights (units): 4,4,4,4,5 (32.5"H), 4,4,5,5,5 (35"H).



D5106

H	D	W
30"	24"	30"
32.5"	29"	33"
35"	35"	36"
		42"
		45"
		48"

Five drawer paper storage cabinet with 150 lb slides.

Drawer Heights (units): 4,4,4,4,4 (30"H), 4,4,4,5,5 (32.5"H), 4,5,5,5,5 (35"H).

Base Cabinets - Drawer Units



D5200

H	D	W
30"	14"	24"
32.5"	18"	27"
35"	24"	30"
	29"	33"
		36"
		39"
		42"
		45"
		48"

Ten drawer base cabinet with two stacks of five drawers.

Drawer Heights (units): 4,4,4,4,4 (30"H), 4,4,4,5,5 (32.5"H), 4,5,5,5,5 (35"H).

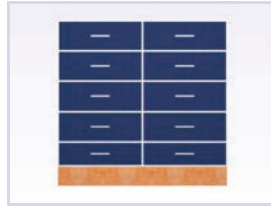

D5202

H	D	W
33"	14"	24"
35"	18"	27"
	24"	30"
	29"	33"
		36"
		39"
		42"
		45"
		48"

Ten drawer base cabinet with two stacks of five drawers. The top row of drawers is always 5u high.

Drawer Heights (units): 5,5,4,4,4 (32.5"H), 5,5,5,5,4 (35"H).



D6100

H	D	W
35"	14"	24"
	18"	27"
	24"	30"
	29"	33"
		36"
		39"
		42"
		45"
		48"

Six drawer base cabinet with equal drawers.

Drawer Heights (units): 4,4,4,4,4,4 (35"H).

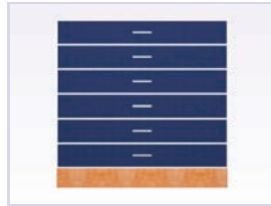

D6102

H	D	W
35"	24"	30"
	29"	33"
	35"	36"
		39"
		42"
		45"
		48"

Six drawer paper storage cabinet with 150 lb slides.

Drawer Heights (units): 4,4,4,4,4,4 (35"H).

Base Cabinets - Combination Units



E2100

H	D	W	Combination base cabinet with one 5u drawer and one door. (Left hinged)
30"	14"	12"	
32.5"	18"	15"	
35"	24"	18"	
	29"	21"	
		24"	



E2101

H	D	W	Combination base cabinet with one 5u drawer and one door. (Right hinged)
30"	14"	12"	
32.5"	18"	15"	
35"	24"	18"	
	29"	21"	
		24"	



E2102

H	D	W	Combination base cabinet with one 5u drawer above an open section with one adjustable shelf.
30"	14"	12"	
32.5"	18"	15"	
35"	24"	18"	
	29"	21"	
		24"	



E2200

H	D	W	Combination base cabinet with one 5u drawer above double doors with one adjustable shelf.
30"	14"	24"	
32.5"	18"	27"	
35"	24"	30"	
	29"	33"	
		36"	

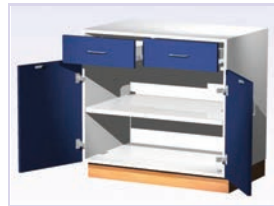

E2202

H	D	W	Combination base cabinet with one row of two 5u drawers above double doors with one adjustable shelf.
30"	14"	24"	
32.5"	18"	27"	
35"	24"	30"	
	29"	33"	
		36"	

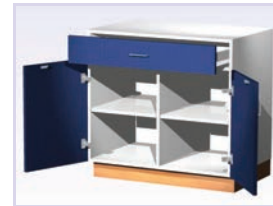

E2204

H	D	W	Combination base cabinet with one 5u drawer above double doors. The door section is split with a vertical division and has one row of adjustable shelves.
30"	14"	24"	
32.5"	18"	27"	
35"	24"	30"	
	29"	33"	
		36"	
		39"	
		42"	
		45"	
		48"	

Base Cabinets - Combination Units

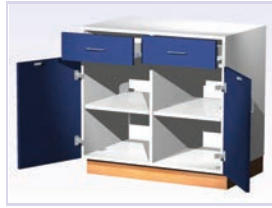

E2206

H	D	W
30"	14"	24"
32.5"	18"	27"
35"	24"	30"
	29"	33"
		36"
		39"
		42"
		45"
		48"

Combination base cabinet with one row of two 5u drawers above double doors. The door section is split with a vertical division and has one row of adjustable shelves.



E2208

H	D	W
30"	14"	24"
32.5"	18"	27"
35"	24"	30"
	29"	33"
		36"

Combination base cabinet with one row of two 5u drawers above an open section with one adjustable shelf.



E2210

H	D	W
30"	14"	24"
32.5"	18"	27"
35"	24"	30"
	29"	33"
		36"
		39"
		42"
		45"
		48"

Combination base cabinet with one row of two 5u drawers above an open section. The open section is split with a vertical division and has one row of adjustable shelves.



E2800

H	D	W
30"	14"	42"
32.5"	18"	45"
35"	24"	48"
	29"	

Combination base blind corner cabinet with 5u drawer, one door, and one fixed shelf. (Left hinged)



E2801

H	D	W
30"	14"	42"
32.5"	18"	45"
35"	24"	48"
	29"	

Combination base blind corner cabinet with 5u drawer, one door, and one fixed shelf. (Right hinged)

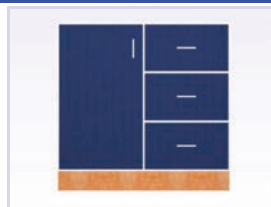

E3200

H	D	W
30"	14"	24"
32.5"	18"	27"
35"	24"	30"
	29"	33"
		36"
		39"
		42"
		45"
		48"

Combination base cabinet with a single door and an adjustable shelf on the left, and three drawers on the right. (Left hinged)

Drawer Heights (units): 6,7,7 (30"H), 7,7,8 (32.5"H), 8,8,8 (35"H).

Base Cabinets - Combination Units



E3201

H	D	W
30"	14"	24"
32.5"	18"	27"
35"	24"	30"
	29"	33"
		36"
		39"
		42"
		45"
		48"

Combination base cabinet with three drawers on the left, and a single door and an adjustable shelf on the right. (Right hinged)

Drawer Heights (units): 6,7,7 (30"H), 7,7,8 (32.5"H), 8,8,8 (35"H).



E3202

H	D	W
30"	14"	24"
32.5"	18"	27"
35"	24"	30"
	29"	33"
		36"
		39"
		42"
		45"
		48"

Combination base cabinet with a single door and an adjustable shelf on the left, and three drawers on the right. The top drawer is always 5u high. (Left hinged)

Drawer Heights (units): 5,7,8 (30"H), 5,8,9 (32.5"H), 5,9,10 (35"H).



E3203

H	D	W
30"	14"	24"
32.5"	18"	27"
35"	24"	30"
	29"	33"
		36"
		39"
		42"
		45"
		48"

Combination base cabinet with three drawers on the left, and a single door and an adjustable shelf on the right. The top drawer is always 5u high. (Right hinged)

Drawer Heights (units): 5,7,8 (30"H), 5,8,9 (32.5"H), 5,9,10 (35"H).



E3204

H	D	W
30"	14"	24"
32.5"	18"	27"
35"	24"	30"
	29"	33"
		36"
		39"
		42"
		45"
		48"

Combination base cabinet with one row of two 5u drawers at the top. Below is a single door and an adjustable shelf on the left, and two additional drawers on the right. (Left hinged)

Drawer Heights (units): 5,7,8 (30"H), 5,8,9 (32.5"H), 5,9,10 (35"H).



E3205

H	D	W
30"	14"	24"
32.5"	18"	27"
35"	24"	30"
	29"	33"
		36"
		39"
		42"
		45"
		48"

Combination base cabinet with one row of two 5u drawers at the top. Below are two additional drawers on the left, and a single door and an adjustable shelf on the right. (Right hinged)

Drawer Heights (units): 5,7,8 (30"H), 5,8,9 (32.5"H), 5,9,10 (35"H).



E4200

H	D	W
30"	14"	24"
32.5"	18"	27"
35"	24"	30"
	29"	33"
		36"
		39"
		42"
		45"
		48"

Combination base cabinet with a door and an adjustable shelf on the left, and four drawers on the right. (Left hinged)

Drawer Heights (units): 5,5,5,5 (30"H), 5,5,6,6 (32.5"H), 6,6,6,6 (35"H).

Base Cabinets - Combination Units



E4201

H	D	W
30"	14"	24"
32.5"	18"	27"
35"	24"	30"
	29"	33"
		36"
		39"
		42"
		45"
		48"

Combination base cabinet with four drawers on the left, and a door and an adjustable shelf on the right. (Right hinged)

Drawer Heights (units): 5,5,5,5 (30"H), 5,5,6,6 (32.5"H), 6,6,6,6 (35"H).



E4202

H	D	W
35"	14"	24"
	18"	27"
	24"	30"
	29"	33"
		36"
		39"
		42"
		45"
		48"

Combination base cabinet with a door and an adjustable shelf on the left, and four drawers on the right. The top drawer is 5u high. (Left hinged)

Drawer Heights (units): 5,6,6,7 (35"H).



E4203

H	D	W
35"	14"	24"
	18"	27"
	24"	30"
	29"	33"
		36"
		39"
		42"
		45"
		48"

Combination base cabinet with four drawers on the left, and a door and an adjustable shelf on the right. The top drawer is 5u high. (Right hinged)

Drawer Heights (units): 5,6,6,7 (35"H).



E4204

H	D	W
30"	14"	24"
32.5"	18"	27"
35"	24"	30"
	29"	33"
		36"
		39"
		42"
		45"
		48"

Combination base cabinet with one row of two 5u drawers at the top. Below is a single door and an adjustable shelf on the left, and three additional drawers on the right. (Left hinged)

Drawer Heights (units): 5,5,5,5 (30"H), 5,5,6,6 (32.5"H), 5,6,6,7 (35"H).



E4205

H	D	W
30"	14"	24"
32.5"	18"	27"
35"	24"	30"
	29"	33"
		36"
		39"
		42"
		45"
		48"

Combination base cabinet with one row of two 5u drawers at the top. Below are three additional drawers on the left, and a single door and an adjustable shelf on the right. (Right hinged)

Drawer Heights (units): 5,5,5,5 (30"H), 5,5,6,6 (32.5"H), 5,6,6,7 (35"H).



E5200

H	D	W
32.5"	14"	24"
35"	18"	27"
	24"	30"
	29"	33"
		36"
		39"
		42"
		45"
		48"

Combination base cabinet with a door and an adjustable shelf on the left, and five drawers on the right. (Left hinged)

Drawer Heights (units): 5,5,4,4,4 (32.5"H), 5,5,5,5,4 (35"H).

Base Cabinets - Combination Units



E5201

H	D	W
32.5"	14"	24"
35"	18"	27"
	24"	30"
	29"	33"
		36"
		39"
		42"
		45"
		48"

Combination base cabinet with five drawers on the left, and a door and an adjustable shelf on the right. (Right hinged)

Drawer Heights (units): 5,5,4,4,4 (32.5"H), 5,5,5,5,4 (35"H).



E5202

H	D	W
32.5"	14"	24"
35"	18"	27"
	24"	30"
	29"	33"
		36"
		39"
		42"
		45"
		48"

Combination base cabinet with one row of two 5u drawers at the top. Below is a single door and an adjustable shelf on the left, and four additional drawers on the right. (Left hinged)

Drawer Heights (units): 5,5,4,4,4 (32.5"H), 5,5,5,5,4 (35"H).



E5203

H	D	W
32.5"	14"	24"
35"	18"	27"
	24"	30"
	29"	33"
		36"
		39"
		42"
		45"
		48"

Combination base cabinet with one row of two 5u drawers at the top. Below are four additional drawers on the left, and a single door and an adjustable shelf on the right. (Right hinged)

Drawer Heights (units): 5,5,4,4,4 (32.5"H), 5,5,5,5,4 (35"H).

Base Cabinets - Sink Units

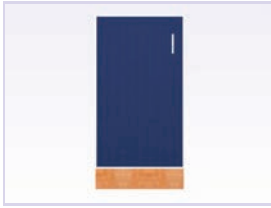

S1100

H	D	W
30"	14"	15"
32.5"	18"	18"
35"	24"	21"
	29"	24"

Single door sink cabinet. The back panel is removable. (Left hinged)

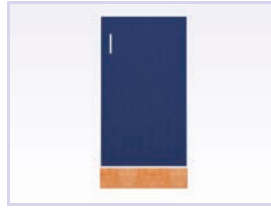

S1101

H	D	W
30"	14"	15"
32.5"	18"	18"
35"	24"	21"
	29"	24"

Single door sink cabinet. The back panel is removable. (Right hinged)

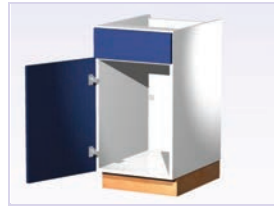
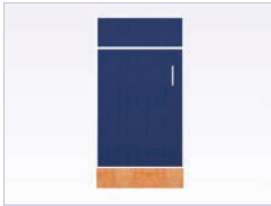

S1102

H	D	W
30"	14"	15"
32.5"	18"	18"
35"	24"	21"
	29"	24"

Single door sink cabinet with a 5u high fixed panel above the door. The back panel is removable. (Left hinged)



S1103

H	D	W
30"	14"	15"
32.5"	18"	18"
35"	24"	21"
	29"	24"

Single door sink cabinet with a 5u high fixed panel above the door. The back panel is removable. (Right hinged)

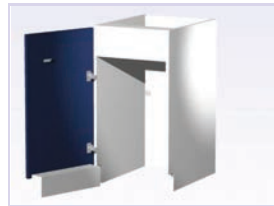

S1104

H	D	W
30"	14"	15"
32.5"	18"	18"
35"	24"	21"
	29"	24"

Sink cabinet with no bottom panel. The back panel is removable. (Left hinged)



S1105

H	D	W
30"	14"	15"
32.5"	18"	18"
35"	24"	21"
	29"	24"

Sink cabinet with no bottom panel. The back panel is removable. (Right hinged)

Base Cabinets - Sink Units

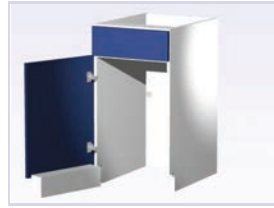

S1106

H	D	W
30"	14"	15"
32.5"	18"	18"
35"	24"	21"
	29"	24"

Sink cabinet with a 5u high fixed panel above the door. The back panel is removable. (Left hinged)



S1107

H	D	W
30"	14"	15"
32.5"	18"	18"
35"	24"	21"
	29"	24"

Sink cabinet with a 5u high fixed panel above the door. The back panel is removable. (Right hinged)

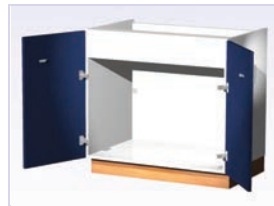

S1200

H	D	W
30"	14"	24"
32.5"	18"	27"
35"	24"	30"
	29"	33"
		36"
		39"
		42"
		45"
		48"

Double door sink cabinet. The back panel is removable.

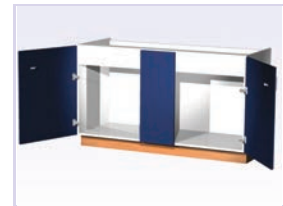
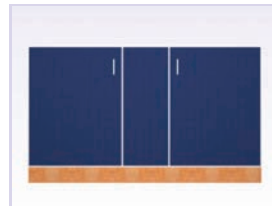

S1202

H	D	W
30"	14"	54"
32.5"	18"	57"
35"	24"	60"
	29"	

Double door sink cabinet with fixed panel between two 24" doors. The back panel is removable.

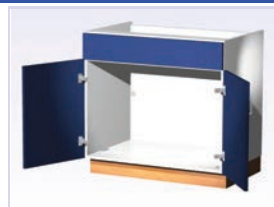

S1204

H	D	W
30"	14"	24"
32.5"	18"	27"
35"	24"	30"
	29"	33"
		36"
		39"
		42"
		45"
		48"

Double door sink cabinet with 5u high fixed panel above the doors. The back panel is removable.



S1206

H	D	W
30"	14"	54"
32.5"	18"	57"
35"	24"	60"
	29"	

Double door sink cabinet with 5u high fixed panel above and another fixed panel between two 24" doors. The back panel is removable.

Base Cabinets – Sink Units



S1208

H	D	W
30"	14"	24"
32.5"	18"	27"
35"	24"	30"
	29"	33"
		36"
		39"
		42"
		45"
		48"

Sink cabinet with two doors and no bottom panel. The back panel is removable.

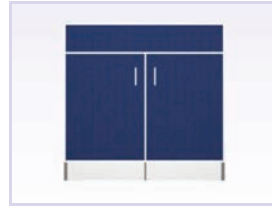

S1210

H	D	W
30"	14"	24"
32.5"	18"	27"
35"	24"	30"
	29"	33"
		36"
		39"
		42"
		45"
		48"

Sink cabinet with two doors and a 5u high fixed panel above. There is no bottom panel. The back panel is removable.

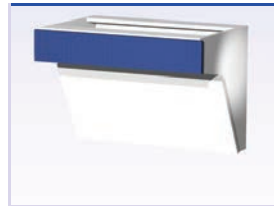

S1900

H	D	W
23"	24"	30"
		33"
		36"
		39"
		42"
		45"
		48"

ADA compliant suspended sink cabinet with a false front and a removable sloped panel.



S1902

H	D	W
32.5"	24"	30"
		33"
		36"
		39"
		42"
		45"
		48"

ADA compliant floor mounted sink cabinet with a false front and a removable sloped panel.



S3200

H	D	W
30"	14"	24"
32.5"	18"	27"
35"	24"	30"
	29"	33"
		36"

Sliding door sink cabinet with a 5u high fixed panel above. The back panel is removable.

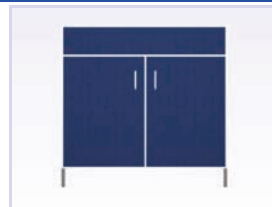

S5200

H	D	W
30"	14"	24"
32.5"	18"	27"
35"	24"	30"
	29"	33"
		36"

Pocket door sink cabinet with no bottom panel. The back panel is removable.

Wall Cabinet Construction Detail

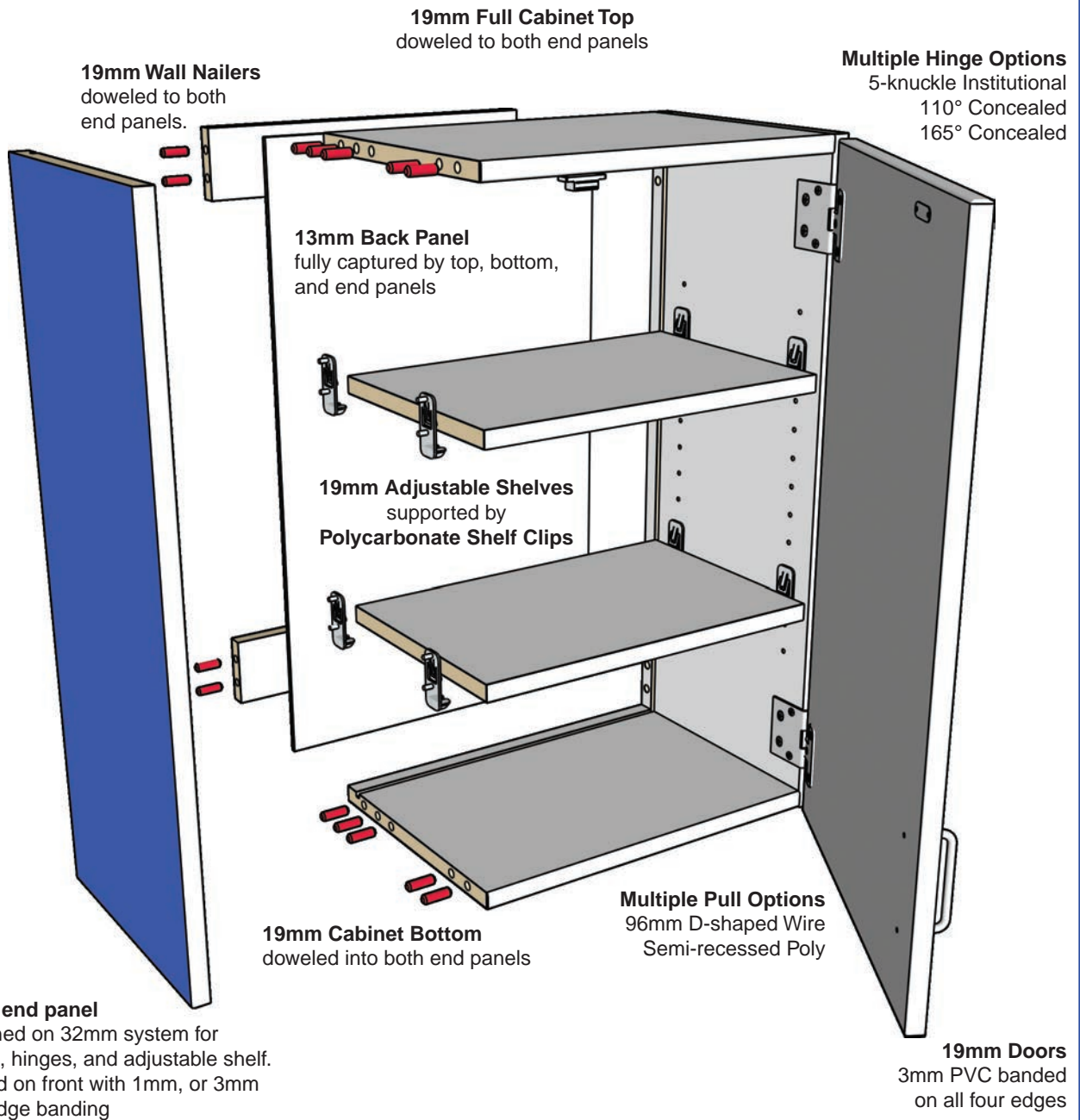

W1105 Wall Cabinet

Wall Cabinets

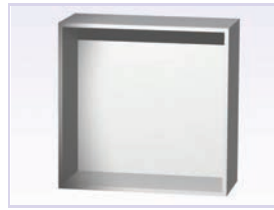

W0000

H	D	W	
18"	13"	12"	Open wall cabinet.
24"		15"	
30"		18"	
36"		21"	
		24"	
		27"	
		30"	
		33"	
		36"	

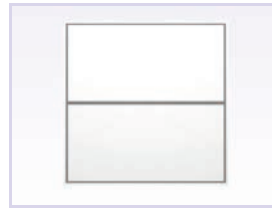

W0002

H	D	W	
18"	13"	12"	Open wall cabinet. The 18" and 24" have one adjustable shelf; the 30" and 36" have two.
24"		15"	
30"		18"	
36"		21"	
		24"	
		27"	
		30"	
		33"	
		36"	



W0004

H	D	W	
18"	13"	24"	Open wall cabinet with one vertical division.
24"		27"	
30"		30"	
36"		33"	
		36"	
		39"	
		42"	
		45"	
		48"	



W0006

H	D	W	
18"	13"	24"	Open wall cabinet with one vertical division. The 18" and 24" have one row of adjustable shelves; the 30" and 36" have two rows.
24"		27"	
30"		30"	
36"		33"	
		36"	
		39"	
		42"	
		45"	
		48"	



W0008

H	D	W	
18"	13"	12"	Open wall cabinet with one fixed shelf, creating two equal compartments.
24"		15"	
30"		18"	
36"		21"	
		24"	
		27"	
		30"	
		33"	
		36"	



W0010

H	D	W	
18"	13"	30"	Open wall cabinet with two vertical divisions. The 18" and 24" have one row of adjustable shelves; the 30" and 36" have two rows.
24"		33"	
30"		36"	
36"		39"	
		42"	
		45"	
		48"	

Wall Cabinets



W0012

H	D	W
18"	13"	24"
24"		27"
30"		30"
36"		33"
		36"
		39"
		42"
		45"
	48"	

Open wall cabinet with one vertical division and one row of fixed shelves, creating four equal compartments.

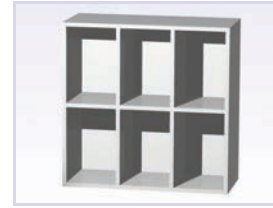

W0014

H	D	W
18"	13"	30"
24"		33"
30"		36"
36"		39"
		42"
		45"
		48"

Open wall cabinet with two vertical divisions and one row of fixed shelves, creating six equal compartments.

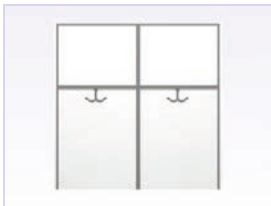

W0016

H	D	W
30"	13"	24"
36"		27"
42"		30"
48"		33"
54"		36"
60"		

Open wall locker cubbie with a vertical division, two equal 300mm (11-3/4") high compartments at the top and two double coat hooks below.

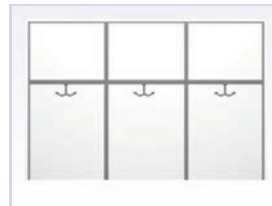

W0018

H	D	W
30"	13"	30"
36"		33"
42"		36"
48"		39"
54"		42"
60"		45"
		48"

Open wall locker cubbie with two vertical divisions, three equal 300mm (11-3/4") high compartments at the top and three double coat hooks below.



W0020

H	D	W
30"	13"	36"
36"		39"
42"		42"
48"		45"
54"		48"
60"		51"
		54"

Open wall locker cubbie with three vertical divisions, four equal 300mm (11-3/4") high compartments at the top and four double coat hooks below.

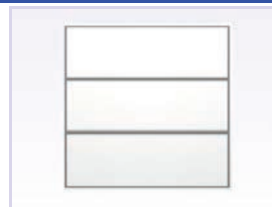

W0022

H	D	W
18"	13"	12"
24"		15"
30"		18"
36"		21"
		24"
		27"
		30"
		33"
	36"	

Open wall cabinet with two fixed shelves, creating three equal compartments.

Wall Cabinets



W0024

H	D	W
18"	13"	12"
24"		15"
30"		18"
36"		

Open wall folio cabinet with multiple 6mm (1/4") adjustable horizontal dividers spaced equally to provide 58mm (2-1/4") high compartments.

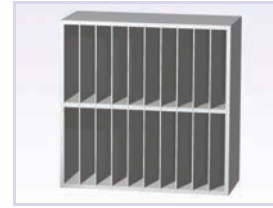

W0026

H	D	W
18"	13"	12"
24"		15"
30"		18"
36"		21"
		24"
		27"
		30"
		33"
	36"	

Open wall folio cabinet with one horizontal division and multiple 6mm (1/4") adjustable vertical dividers spaced equally to provide 58mm (2-1/4") wide compartments.

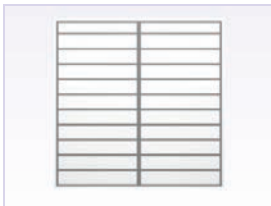

W0028

H	D	W
18"	13"	21"
24"		24"
30"		27"
36"		30"
		33"
		36"

Open wall folio cabinet with one vertical division and multiple 6mm (1/4") adjustable horizontal dividers spaced equally to provide 58mm (2-1/4") high compartments.

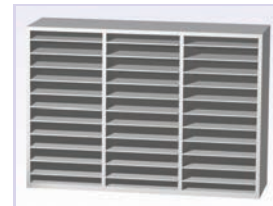
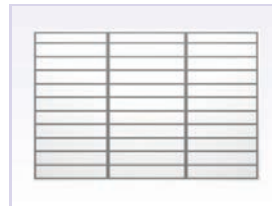

W0030

H	D	W
18"	13"	30"
24"		33"
30"		36"
36"		39"
		42"
		45"
		48"

Open wall folio cabinet with two vertical divisions and multiple 6mm (1/4") adjustable horizontal dividers spaced equally to provide 58mm (2-1/4") high compartments.

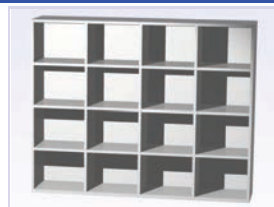

W0032

H	D	W

Wall mounted mail slots with 19mm (3/4") horizontal and vertical divisions.

Specify number and size of compartments required.



W0800

H	D	W
18"	26"	26"
24"		
30"		
36"		

Open corner wall cabinet with one fixed shelf.

Wall Cabinets



W1100

H	D	W	
18"	14"	12"	Single door wall cabinet. (Left hinged)
24"		15"	
30"		18"	
36"		21"	
		24"	



W1101

H	D	W	
18"	14"	12"	Single door wall cabinet. (Right hinged)
24"		15"	
30"		18"	
36"		21"	
		24"	



W1102

H	D	W	
18"	14"	12"	Single door wall cabinet. The 18" and 24" have one adjustable shelf; the 30" and 36" have two. (Left hinged)
24"		15"	
30"		18"	
36"		21"	
		24"	



W1103

H	D	W	
18"	14"	12"	Single door wall cabinet. The 18" and 24" have one adjustable shelf; the 30" and 36" have two. (Right hinged)
24"		15"	
30"		18"	
36"		21"	
		24"	

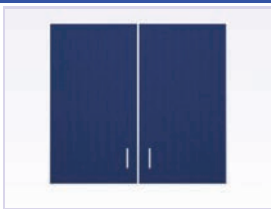

W1200

H	D	W	
18"	14"	24"	Double door wall cabinet.
24"		27"	
30"		30"	
36"		33"	
		36"	



W1202

H	D	W	
18"	14"	24"	Double door wall cabinet. The 18" and 24" have one adjustable shelf; the 30" and 36" have two.
24"		27"	
30"		30"	
36"		33"	
		36"	

Wall Cabinets

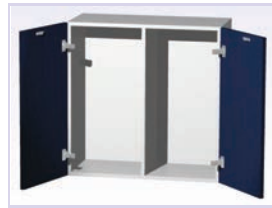
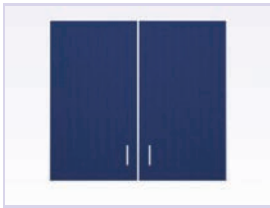

W1204

H	D	W	
18"	14"	24"	Double door wall cabinet with one vertical division.
24"		27"	
30"		30"	
36"		33"	
		36"	
		39"	
		42"	
		45"	
		48"	

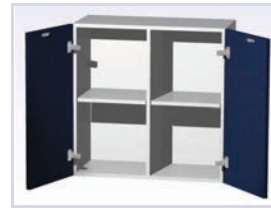

W1206

H	D	W	
18"	14"	24"	Double door wall cabinet with one vertical division. The 18" and 24" have one row of adjustable shelves; the 30" and 36" have two rows.
24"		27"	
30"		30"	
36"		33"	
		36"	
		39"	
		42"	
		45"	
		48"	



W1208

H	D	W	
42"	14"	12"	Wall cabinet with two doors separated by a horizontal division. The upper and lower sections each contain an adjustable shelf. (Left hinged)
48"		15"	
54"		18"	
		21"	
		24"	



W1209

H	D	W	
42"	14"	12"	Wall cabinet with two doors separated by a horizontal division. The upper and lower sections each contain an adjustable shelf. (Right hinged)
48"		15"	
54"		18"	
		21"	
		24"	

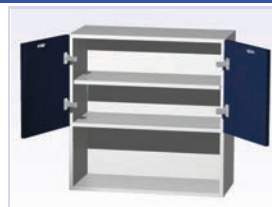
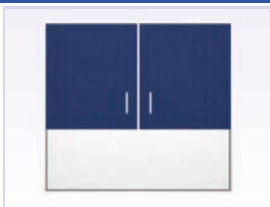

W1210

H	D	W	
24"	14"	24"	Double door wall cabinet with one adjustable shelf. Below is a 300mm (11-3/4") high open compartment.
30"		27"	
36"		30"	
		33"	
		36"	

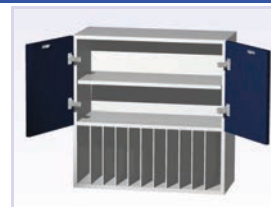
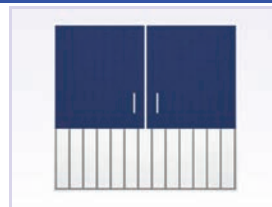

W1212

H	D	W	
24"	14"	24"	Double door wall cabinet with one adjustable shelf. Below is a 300mm (11-3/4") high open compartment with 6mm (1/4") adjustable vertical dividers spaced equally to provide 58mm (2-1/4") wide compartments.
30"		27"	
36"		30"	
		33"	
		36"	

Wall Cabinets

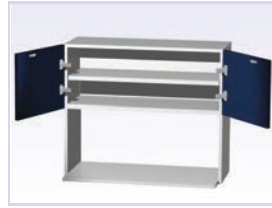
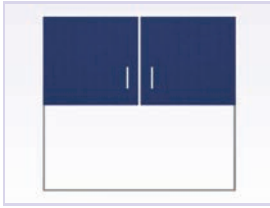

W1214

H	D	W
24"	14"	30"
30"		36"
36"		

Double door microwave storage wall cabinet with one adjustable shelf. The microwave compartment is a 380mm (14-7/8") high opening with a 456mm (18") extended bottom.



W1402

H	D	W
42"	14"	24"
48"		27"
54"		30"
		33"
		36"

Four door wall cabinet with a full width fixed shelf. Both the upper and lower portions include an adjustable shelf.



W1406

H	D	W
42"	14"	24"
48"		27"
54"		30"
		33"
		36"
		39"
		42"
		45"
		48"

Four door wall cabinet with a vertical division and one row of fixed shelves. Each of the four compartments include an adjustable shelf.



W1800

H	D	W
18"	14"	27"
24"		30"
30"		33"
36"		36"
		39"

Blind corner wall cabinet with one fixed shelf. (Left hinged)



W1801

H	D	W
18"	14"	27"
24"		30"
30"		33"
36"		36"
		39"

Blind corner wall cabinet with one fixed shelf. (Right hinged)

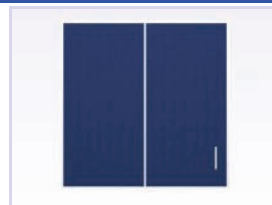

W1802

H	D	W
18"	14"	27"
24"		30"
30"		33"
36"		36"
		39"

Blind corner wall cabinet with a fixed panel on the left and one fixed shelf. (Left hinged)

Wall Cabinets

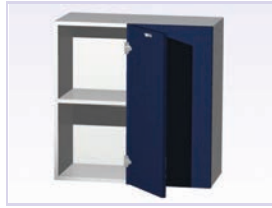
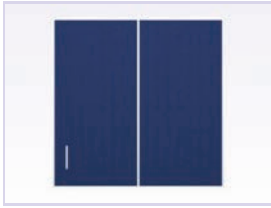

W1803

H	D	W
18"	14"	27"
24"		30"
30"		33"
36"		36"
		39"

Blind corner wall cabinet with a fixed panel on the left and one fixed shelf. (Right hinged)

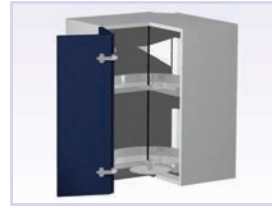

W1804

H	D	W
18"	25"	25"
24"		
30"		
36"		

Corner wall cabinet with a square face and two revolving polymer shelves. (Left hinged)



W1805

H	D	W
18"	25"	25"
24"		
30"		
36"		

Corner wall cabinet with a square face and two revolving polymer shelves. (Right hinged)

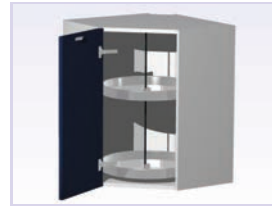

W1806

H	D	W
18"	25"	25"
24"		
30"		
36"		

Corner wall cabinet with a chamfered face and two revolving polymer shelves. (Left hinged)

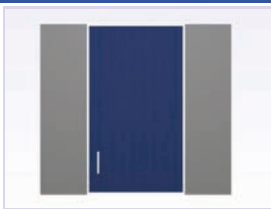

W1807

H	D	W
18"	25"	25"
24"		
30"		
36"		

Corner wall cabinet with a chamfered face and two revolving polymer shelves. (Right hinged)

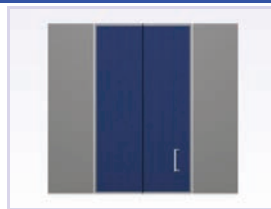

W1808

H	D	W
18"	25"	25"
24"		
30"		
36"		

Corner wall cabinet with a square face and one fixed shelf. (Left hinged)

Wall Cabinets

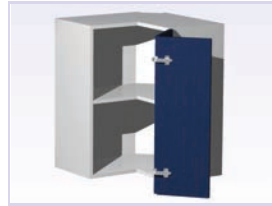

W1809

H	D	W
18"	25"	25"
24"		
30"		
36"		

Corner wall cabinet with a square face and one fixed shelf. (Right hinged)

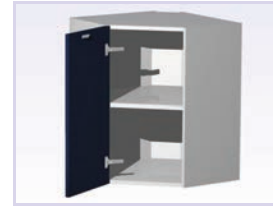

W1810

H	D	W
18"	25"	25"
24"		
30"		
36"		

Corner wall cabinet with a chamfered face and one fixed shelf. (Left hinged)



W1811

H	D	W
18"	25"	25"
24"		
30"		
36"		

Corner wall cabinet with a chamfered face and one fixed shelf. (Right hinged)



W2102

H	D	W
18"	14"	15"
24"		18"
30"		21"
36"		24"

Glass door wall cabinet with 6mm (1/4") laminated safety glass. The 18" and 24" have one adjustable shelf; the 30" and 36" have two. (Left hinged)



W2103

H	D	W
18"	14"	15"
24"		18"
30"		21"
36"		24"

Glass door wall cabinet with 6mm (1/4") laminated safety glass. The 18" and 24" have one adjustable shelf; the 30" and 36" have two. (Right hinged)



W2202

H	D	W
18"	14"	30"
24"		33"
30"		36"
36"		

Double glass door wall cabinet with 6mm (1/4") laminated safety glass. The 18" and 24" have one adjustable shelf; the 30" and 36" have two.

Wall Cabinets



W2206

H	D	W
18"	14"	30"
24"		33"
30"		36"
36"		39"
		42"
		45"
		48"

Double glass door wall cabinet with one vertical division. Uses 6mm (1/4") laminated safety glass. The 18" and 24" have one row of adjustable shelves; the 30" and 36" have two rows.



W2402

H	D	W
42"	14"	30"
48"		33"
54"		36"

Four glass door wall cabinet with a full width fixed shelf. Both the upper and lower portions include an adjustable shelf. Uses 6mm (1/4") laminated safety glass.



W2406

H	D	W
42"	14"	30"
48"		33"
54"		36"
		39"
		42"
		45"
		48"

Four glass door wall cabinet with a vertical division and one row of fixed shelves. Each of the four compartments include an adjustable shelf. Uses 6mm (1/4") laminated safety glass.

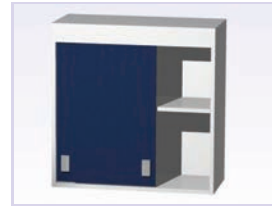

W3202

H	D	W
18"	13"	24"
24"		27"
30"		30"
36"		33"
		36"

Sliding panel door wall cabinet. The 18" and 24" have one adjustable shelf; the 30" and 36" have two.



W3206

H	D	W
18"	13"	30"
24"		33"
30"		36"
36"		39"
		42"
		45"
		48"

Sliding panel door wall cabinet with a vertical division. The 18" and 24" have one row of adjustable shelves; the 30" and 36" have two rows.

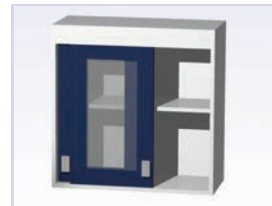

W4202

H	D	W
18"	13"	30"
24"		33"
30"		36"
36"		

Wall cabinet with sliding glass framed doors using 6mm (1/4") laminated safety glass. The 18" and 24" have one adjustable shelf; the 30" and 36" have two.

Wall Cabinets

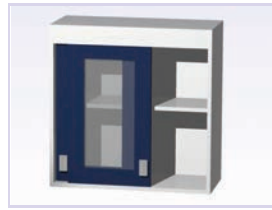

W4206

H	D	W
18"	13"	30"
24"		33"
30"		36"
36"		39"
		42"
		45"
		48"

Wall cabinet with sliding glass framed doors using 6mm (1/4") laminated safety glass. Includes one vertical division. The 18" and 24" have one row of adjustable shelves; the 30" and 36" have two rows.

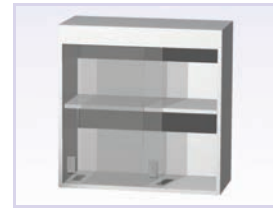

W5202

H	D	W
18"	13"	24"
24"		27"
30"		30"
36"		33"
		36"

Wall cabinet with sliding plate glass doors using 6mm (1/4") laminated safety glass. The 18" and 24" have one adjustable shelf; the 30" and 36" have two.



W5206

H	D	W
18"	13"	30"
24"		33"
30"		36"
36"		39"
		42"
		45"
		48"

Wall cabinet with sliding plate glass doors using 6mm (1/4") laminated safety glass. Includes one vertical division. The 18" and 24" have one row of adjustable shelves; the 30" and 36" have two rows.

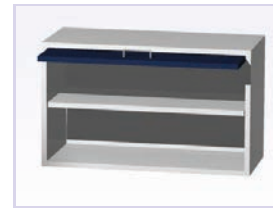
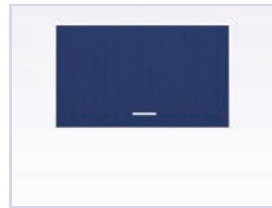

W6102

H	D	W
18"	13"	24"
24"		27"
		30"
		33"
		36"

Wall cabinet with a flip-up pocket door and one adjustable shelf.

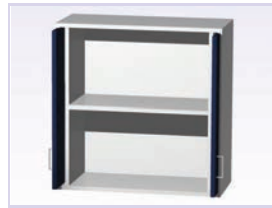
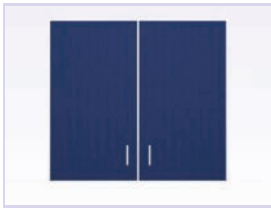

W6202

H	D	W
18"	13"	30"
24"		33"
30"		36"
36"		39"
		42"

Wall cabinet with double pocket doors. The 18" and 24" have one adjustable shelf; the 30" and 36" have two.

Tall Cabinet Construction Detail

19mm end panel

machined on 32mm system for dowels, hinges, and adjustable shelf. Banded on front with 1mm or 3mm PVC edge banding

19mm Wall Nailers

doweled to both end panels.

19mm Full Cabinet Top

doweled to both end panels

13mm Back Panel

fully captured by top, bottom, and end panels

19mm Fixed Center Shelf

doweled into both end panels

19mm Adjustable Shelves

supported by Polycarbonate Shelf Clips

19mm Cabinet Bottom

doweled into both end panels

19mm Doors

3mm PVC banded on all four edges

Multiple Hinge Options

- 5-knuckle Institutional
- 110° Concealed
- 165° Concealed

Multiple Pull Options

- 96mm D-shaped Wire
- Semi-recessed Poly

Plywood Base

fastened to cabinet bottom

T1208 Tall Storage Cabinet

Tall Cabinets

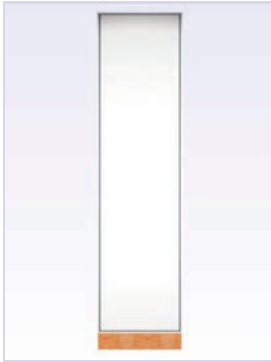

T0000

Open tall cabinet.

H	D	W
72"	13"	12"
84"	17"	15"
	23"	18"
	28"	21"
		24"
		27"
		30"
		33"
		36"

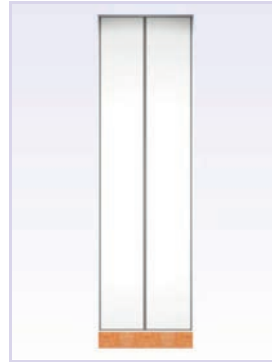

T0002

Open tall cabinet with one vertical division.

H	D	W
72"	13"	24"
84"	17"	27"
	23"	30"
	28"	33"
		36"

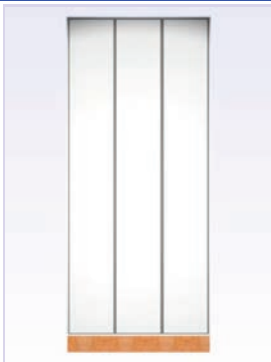

T0004

Open tall cabinet with two vertical divisions.

H	D	W
72"	13"	30"
84"	17"	33"
	23"	36"
	28"	39"
		42"
		45"
		48"

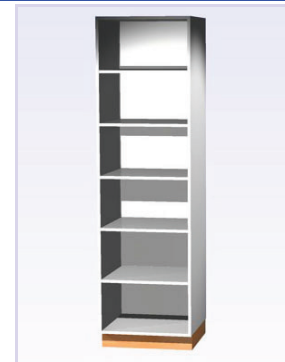
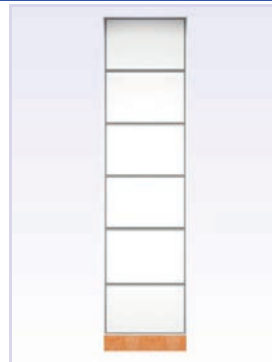

T0006

Open tall cabinet with five fixed shelves, creating six compartments.

H	D	W
72"	13"	12"
84"	17"	15"
	23"	18"
	28"	21"
		24"
		27"
		30"
		33"
		36"

Tall Cabinets

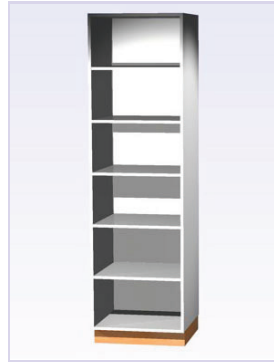
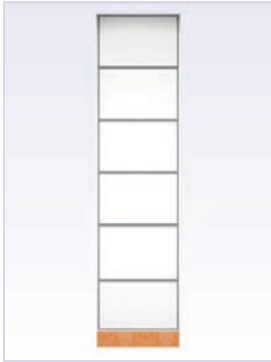

T0008

H	D	W
72"	13"	12"
84"	17"	15"
	23"	18"
	28"	21"
		24"
		27"
		30"
		33"
		36"

Open tall cabinet with one fixed shelf and four adjustable shelves, creating six compartments.

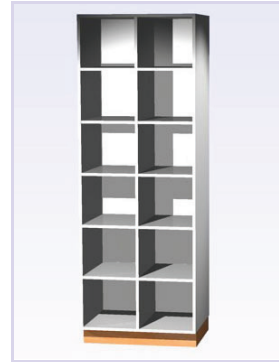
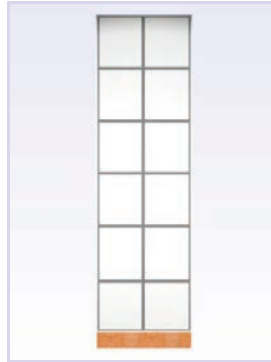

T0010

H	D	W
72"	13"	30"
84"	17"	33"
	23"	36"
	28"	39"
		42"
		45"
		48"

Open tall cabinet with one vertical division and five rows of adjustable shelves, creating 12 compartments.

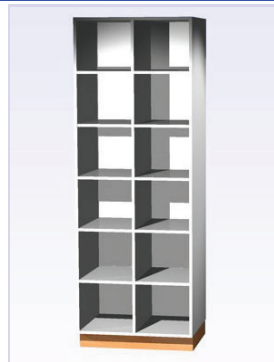
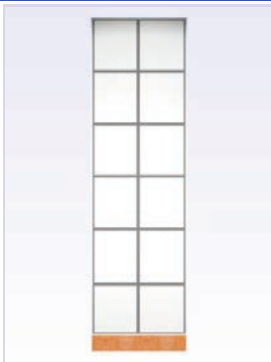

T0012

H	D	W
72"	13"	30"
84"	17"	33"
	23"	36"
	28"	39"
		42"
		45"
		48"

Open tall cabinet with one vertical division, one row of fixed shelves, and four rows of adjustable shelves, creating 12 compartments.

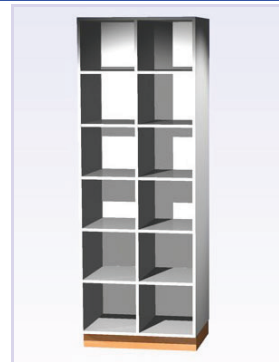
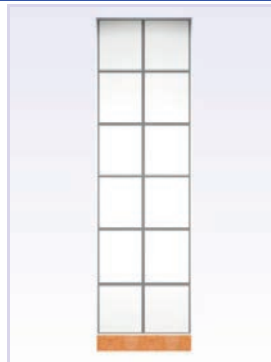

T0014

H	D	W
72"	13"	30"
84"	17"	33"
	23"	36"
	28"	39"
		42"
		45"
		48"

Open tall cabinet with one vertical division and five rows of fixed shelves, creating 12 compartments.

Tall Cabinets

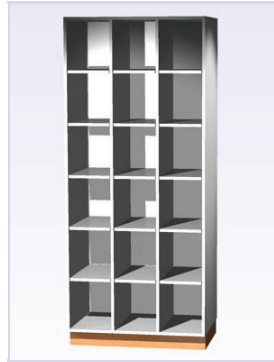
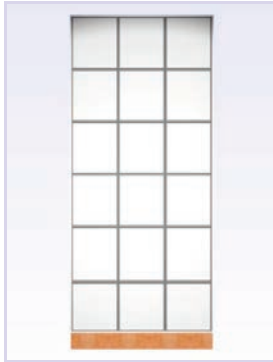

T0016

H	D	W
72"	13"	30"
84"	17"	33"
	23"	36"
	28"	39"
		42"
		45"
		48"

Open tall cabinet with two vertical divisions and five rows of adjustable shelves, creating 18 compartments.

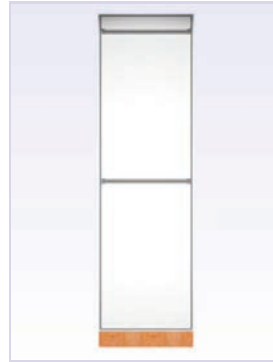

T0018

H	D	W
72"	23"	12"
84"	28"	15"
		18"
		21"
		24"
		27"
		30"
		33"
		36"

Open tall cabinet with two closet rods.

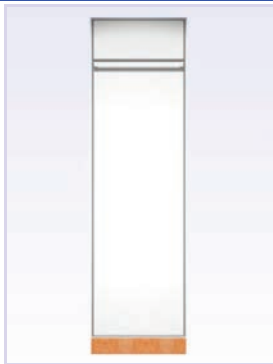

T0020

H	D	W
72"	23"	12"
84"	28"	15"
		18"
		21"
		24"
		27"
		30"
		33"
		36"

Open tall cabinet with a 260mm (10-1/4") high compartment at the top and a closet rod below.

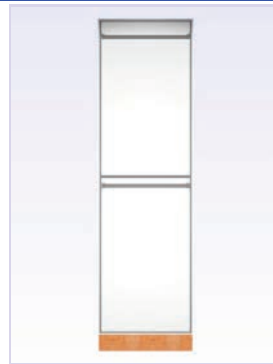

T0022

H	D	W
72"	23"	12"
84"	28"	15"
		18"
		21"
		24"
		27"
		30"
		33"
		36"

Open tall cabinet with a fixed horizontal and two closet rods.

Tall Cabinets

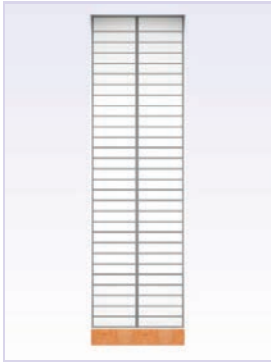

T0024

H	D	W
72"	13"	21"
84"	17"	24"
	23"	27"
		30"
		33"
		36"

Open tall cabinet with one vertical division and 6mm (1/4") adjustable horizontal dividers spaced equally to provide 58mm (2-1/4") high compartments.

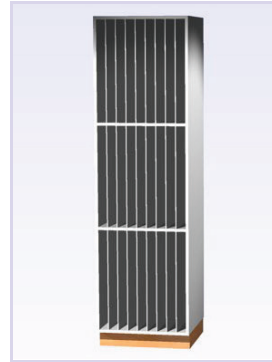
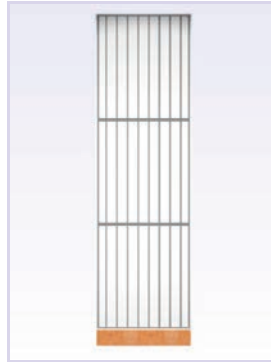

T0026

H	D	W
72"	13"	12"
84"	17"	15"
	23"	18"
		21"
		24"
		27"
		30"
		33"
		36"

Open tall cabinet with two horizontal divisions and 6mm (1/4") adjustable vertical dividers spaced equally to provide 58mm (2-1/4") wide compartments.

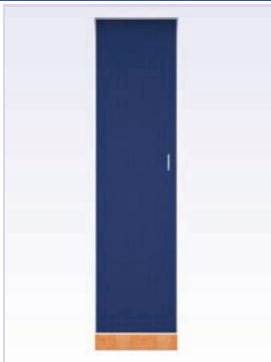

T1108

H	D	W
72"	14"	12"
84"	18"	15"
	24"	18"
	29"	21"
		24"

Single door tall cabinet with one fixed shelf and four adjustable shelves, creating six compartments. (Left hinged)

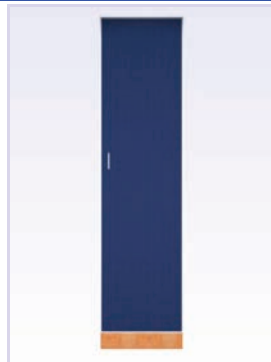

T1109

H	D	W
72"	14"	12"
84"	18"	15"
	24"	18"
	29"	21"
		24"

Single door tall cabinet with one fixed shelf and four adjustable shelves, creating six compartments. (Right hinged)

Tall Cabinets

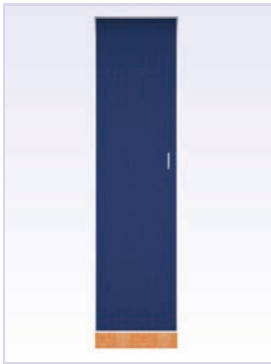

T1116

H	D	W
72"	24"	12"
84"	29"	15"
		18"
		21"
		24"

Single door tall cabinet with one closet rod. (Left hinged)

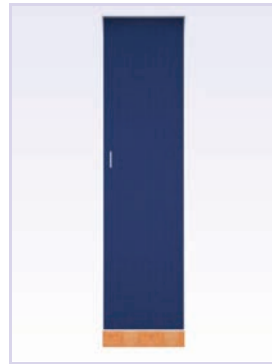

T1117

H	D	W
72"	24"	12"
84"	29"	15"
		18"
		21"
		24"

Single door tall cabinet with one closet rod. (Right hinged)

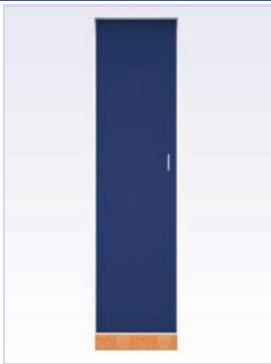

T1118

H	D	W
72"	14"	12"
84"	18"	15"
	24"	18"
	29"	21"
		24"

Single door tall cabinet with 260mm (10-1/4") high compartment at the top supporting double coat hooks below. (Left hinged)

Hooks are spaced at 5-5/8" on center. Quantity is determined by the width of the cabinet.

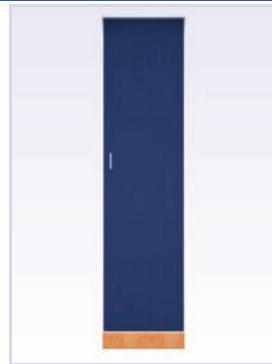

T1119

H	D	W
72"	14"	12"
84"	18"	15"
	24"	18"
	29"	21"
		24"

Single door tall cabinet with 260mm (10-1/4") high compartment at the top supporting double coat hooks below. (Right hinged)

Hooks are spaced at 5-5/8" on center. Quantity is determined by the width of the cabinet.

Tall Cabinets

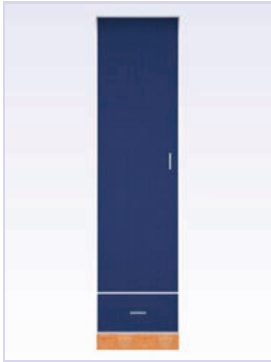

T1120

H	D	W
72"	24"	12"
84"	29"	15"
		18"
		21"
		24"

Single door tall cabinet with 260mm (10-1/4") high compartment at the top, one closet rod below, and one 8u high drawer at the bottom. (Left hinged)

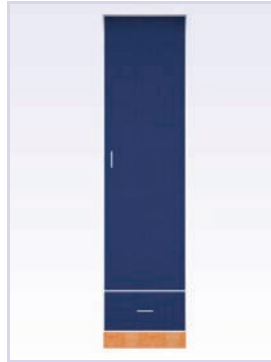

T1121

H	D	W
72"	24"	12"
84"	29"	15"
		18"
		21"
		24"

Single door tall cabinet with 260mm (10-1/4") high compartment at the top, one closet rod below, and one 8u high drawer at the bottom. (Right hinged)

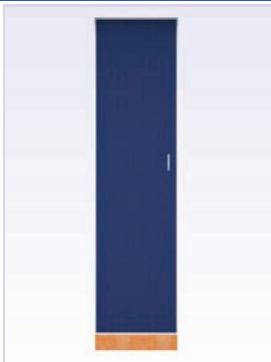

T1122

H	D	W
72"	24"	12"
84"	29"	15"
		18"
		21"
		24"

Single door tall cabinet with 260mm (10-1/4") high compartment at the top and a closet rod below. (Left hinged)

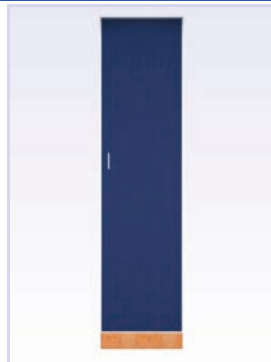

T1123

H	D	W
72"	24"	12"
84"	29"	15"
		18"
		21"
		24"

Single door tall cabinet with 260mm (10-1/4") high compartment at the top and a closet rod below. (Right hinged)

Tall Cabinets

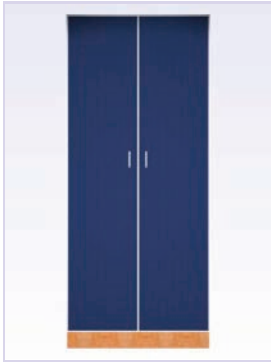

T1208

H	D	W
72"	14"	24"
84"	18"	27"
	24"	30"
	29"	33"
		36"

Double door tall cabinet with one fixed shelf and four adjustable shelves, creating six compartments.

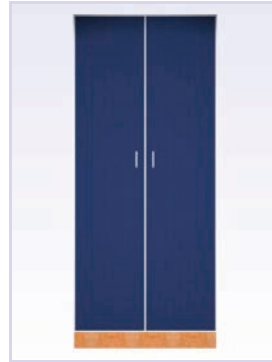

T1212

H	D	W
72"	14"	30"
84"	18"	33"
	24"	36"
	29"	39"
		42"
		45"
		48"

Double door tall cabinet with one vertical division, one row of fixed shelves, and four rows of adjustable shelves, creating 12 compartments.

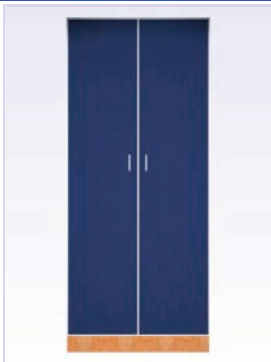

T1216

H	D	W
72"	24"	24"
84"	29"	27"
		30"
		33"
		36"

Double door tall cabinet with 260mm (10-1/4") high compartment at the top and one closet rod below.

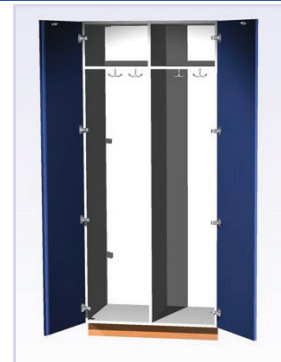
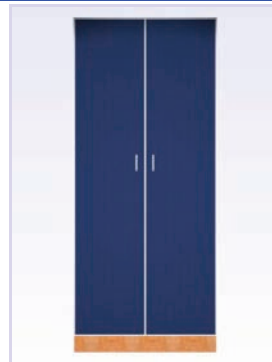

T1218

H	D	W
72"	14"	30"
84"	18"	33"
	24"	36"
	29"	39"
		42"
		45"
		48"

Double door tall cabinet with one vertical division, one row of 260mm (10-1/4") high compartments at the top supporting one row of double coat hooks below.

Hooks are spaced at 5-5/8" on center. Quantity is determined by the width of the cabinet.

Tall Cabinets

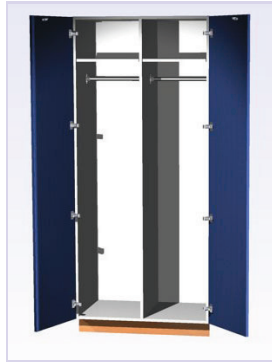
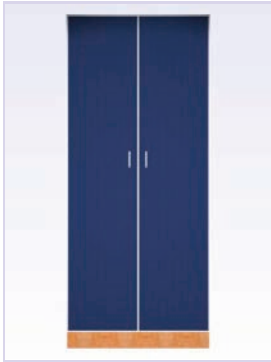

T1220

H	D	W
72"	24"	30"
84"	29"	33"
		36"
		39"
		42"
		45"
		48"

Double door tall cabinet with one vertical division, one row of 260mm (10-1/4") high compartments at the top and one row of closet rods below.

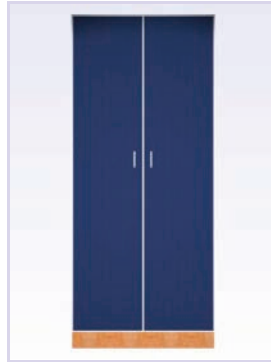

T1222

H	D	W
72"	24"	30"
84"	29"	33"
		36"
		39"
		42"
		45"
		48"

Wardrobe cabinet with one on-center vertical division, a closet rod on the left, and five adjustable shelves on the right. The left door has a mirror and pen tray.

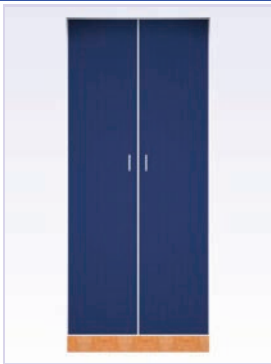

T1224

H	D	W
72"	24"	36"
84"	29"	39"
		42"
		45"
		48"

Wardrobe cabinet with one off-center vertical division, a fixed shelf, and a closet rod on the left, and two adjustable shelves and two file drawers on the right. The left door has a mirror and pen tray.

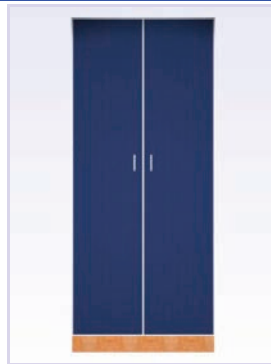

T1226

H	D	W
72"	24"	36"
84"	29"	39"
		42"
		45"
		48"

Wardrobe cabinet with one on-center vertical divider and one row of 260mm (10-1/4") high compartments at the top. The left side has a closet rod. The right side has four adjustable shelves. The left door has a mirror and pen tray.

Tall Cabinets

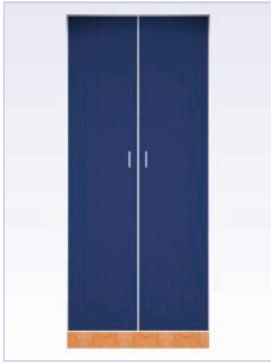

T1228

H	D	W
72"	24"	36"
84"	29"	

Double door tall cabinet with two vertical divisions and type TBD-#1 tote trays. 72" height has 48 trays. 84" height has 57 trays.

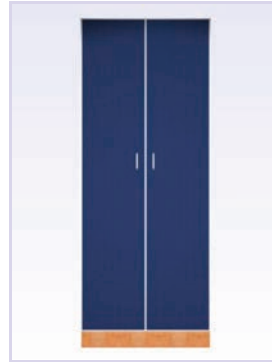

T1230

H	D	W
72"	24"	33"
84"	29"	

Double door tall cabinet with one vertical division and type TBD-#2 tote trays. 72" height has 32 trays. 84" height has 38 trays.

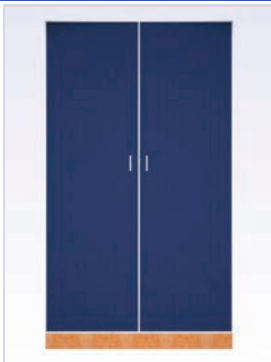

T1232

H	D	W
72"	24"	48"
84"	29"	

Double door tall cabinet with two vertical divisions and type TBD-#2 tote trays. 72" height has 48 trays. 84" height has 57 trays.



T2208

H	D	W
72"	14"	30"
84"	18"	33"
	24"	36"
	29"	

Tall cabinet with one fixed shelf, four adjustable shelves, and two glass-insert doors with 6mm (1/4") laminated safety glass.

Tall Cabinets

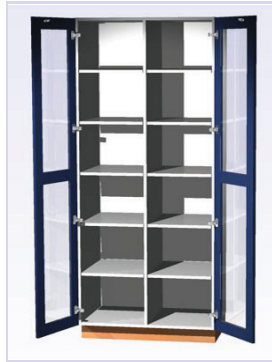
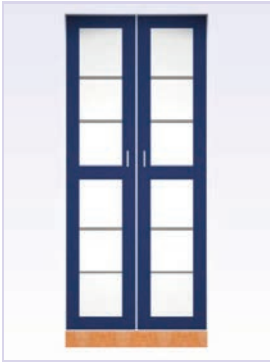

T2212

H	D	W
72"	14"	30"
84"	18"	33"
	24"	36"
	29"	39"
		42"
		45"
		48"

Tall cabinet with one vertical division, one row of fixed shelves, four rows of adjustable shelves, and two glass-insert doors with 6mm (1/4") laminated safety glass.

Fillers

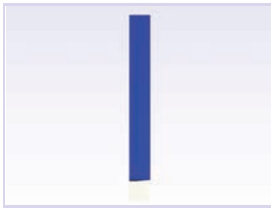

FILB

H	D	W
30"		
32.5"		
35"		

3-piece filler assembly kit for base cabinets. Width is sent oversized and cut to fit in the field.



FILT

H	D	W
72"	23"	
84.5"	28"	

4-piece filler assembly kit for tall cabinets. Width is sent oversized and cut to fit in the field.

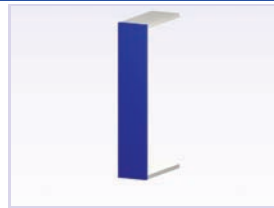

FILW

H	D	W
18.25"	13"	
24.5"		
29.5"		
36"		

3-piece filler assembly kit for wall cabinets. Width is sent oversized and cut to fit in the field.

Trim



Z3100

H	D	W
30"	23"	
32.5"	28"	
36"		

Pedestal panel 3/4" thick with standard toe kick cutout.



Z3102

H	D	W
30"	23"	
32.5"	28"	
36"		

Pedestal panel 1-1/2" thick with standard toe kick cutout.



Z3104

H	D	W
23"	23"	

Wall mounted countertop support with 1" contoured panel and top and back mounting cleats.

Work Tops

Work Top material selections are among the most critical of the furniture decisions. The intended applications for your work tops dictate material choice. Surfaces

could be exposed to reagents and caustic substances. Heavy equipment may need to be supported or only light duty tasks may be performed.

Kewaunee can recommend and furnish materials fabricated to your individual needs, complete with appropriate sinks, drains and accessories.

High Pressure Laminate Work Tops

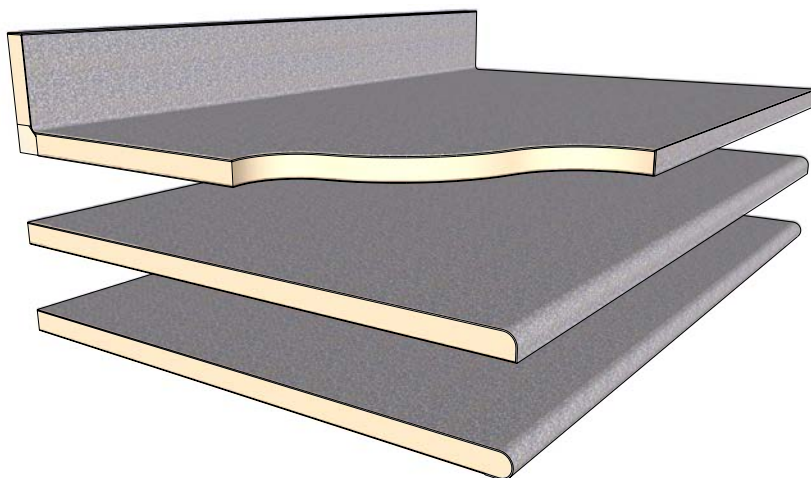

Appearance: Hard smooth surface.

Available Colors: Available in all Formica® and Wilsonart® colors, patterns, and textures

Composition: High pressure laminate surface attached to solid particleboard, plywood, or MDF substrate using water resistant adhesive

Physical Properties: Excellent all around cost effective work surface. Good: scratch, heat, and moisture resistance. Chemical resistant colors are available.

Applications: Recommended for light to medium duty purposes.

Other Work Top Materials

MATERIAL	APPEARANCE	COMPOSITION	PHYSICAL PROPERTIES	APPLICATIONS
KEMRESIN®	Ultra-smooth, non-porous surface Available colors: Grey, Slate, Putty, and Black	1" thick molded epoxy resin	Excellent resistance to practically all acids, alkalis, and solvents. Highly resistant to heat and normal physical abuse.	Use wherever optimum physical and chemical resisting properties are required.
HARDWOOD: OAK or MAPLE	Natural varnish, or penetrating oil finish	Solid edge grain Maple or Oak strips, glued together electronically, and finished with baked-on clear synthetic varnish or penetrating oil.	Warm appearance. Poor heat and scratch resistance but surface is renewable.	Excellent top material for Physics tables, Electronic benches, and other tables where mechanical or physical work levels are prevalent.
COMPOSITE RESIN	Hard, smooth non-glare surface	Cellulose fiber reinforced phenolic resin core with a polyurethane copolymer surface. Available in multiple colors and patterns.	Good chemical resistance to wide range of acids, alkalis and solvents.	Use wherever a high degree of chemical resistance is required.
STAINLESS STEEL	No. 4 Finish	Type 304 furnished as standard, but other types are available when specified. Type 316 supplied for Perchloric Acid fume hoods.	Excellent heat, stain, and scratch resistance. Can be sterilized.	Recommended for food preparation and sterile medical applications.

Work Tops

Specifications:

The configurations shown are for Kewaunee laminate base cabinets. Standard top thickness is 1", standard curb height is 4".

To order, select configuration and top material desired. Specify number of linear or square feet per product.

Dimensions are nominal. Not all configurations are available in all materials. Indented tops available on special order for some materials.

Wall Bench Tops

Top no Curb Style B

Standard	15"
Sizes:	19"
	25"
	30"

Top with Applied Curb Style C

Standard	15"
Sizes:	19"
	25"
	30"

Top with Coved Integral Curb Style D

Standard	15"
Sizes:	19"
	25"
	30"

Corner Top no Curbs Style K

	A	B	C
Standard	28"	19"	9"
Sizes:	34"	25"	9"
	39"	30"	9"

Corner Top with Applied Curbs Style L

	A	B	C
Standard	28"	19"	9"
Sizes:	34"	25"	9"
	39"	30"	9"

Center Bench Tops

Top without Center Joint Style H

	A
Standard	54"
Sizes:	60"
	62"

Top with Center Joint Style I

	A	B	C
Standard	54"	27"	27"
Sizes:	54"	24"	30"
	60"	30"	30"
	62"	41"	31"

Top with Center Ledge Style J

	A	B	C	D
Standard	54"	24"	6"	24"
Sizes:	60"	24"	12"	24"
	62"	24"	14"	24"

Ledges and Shelves

Ledge Unfinished Edges Style A

	A
Standard	8"
Sizes:	10"
	12"
	14"
	16"

Shelf Finished Edges Style N

	A
Standard	8"
Sizes:	10"
	12"
	14"
	16"

Wall Shelving Assemblies

Specifications:

Vertical Uprights are 1 1/4" deep and either 79" or 42" high. They are manufactured with a double-slotted face with slots on 1" centers. They are designed to be mounted between two Support Rails to hold accurate spacing.

Support Rails are available in 8 foot lengths and may be cut to the required length. Support Rails are notched on 6" centers to accept the Vertical Uprights.

Support Rail Covers are required to finish the assembly and must be ordered in pairs to match the Vertical Upright spacing.

Optional Center Rails may be ordered to provide a horizontal member at counter top height. They should be sized to match the Vertical Upright spacing.

Full Height Wall Suspension System

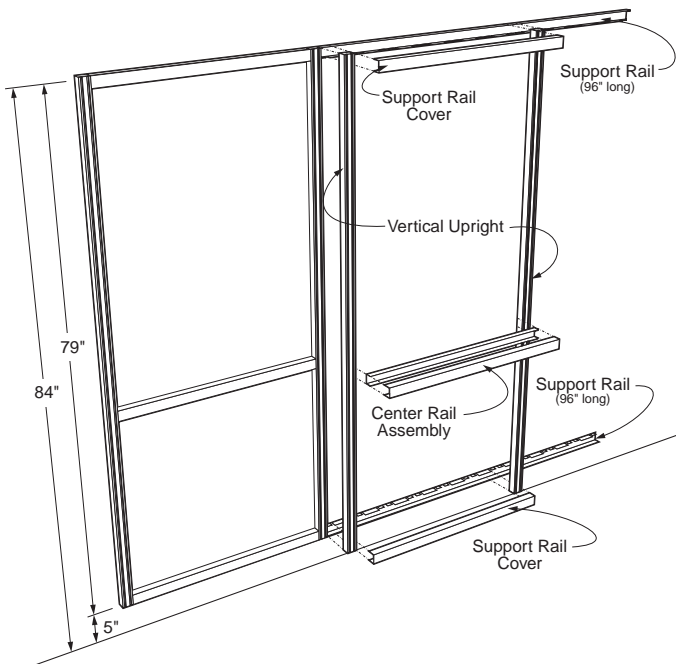

Vertical Upright

F10M0279-00	79"H	pair
--------------------	------	------

Support Rail

F11M0196-00	96"L	each
--------------------	------	------

Support Rail Covers

F11M0324-00	24"L	pair
F11M0330-00	30"L	pair
F11M0336-00	36"L	pair
F11M0342-00	42"L	pair
F11M0348-00	48"L	pair
F11M0354-00	54"L	pair
F11M0360-00	60"L	pair
F11M0366-00	66"L	pair
F11M0372-00	72"L	pair

Optional Center Rail Assembly

F11M0224-00	24"L	each
F11M0230-00	30"L	each
F11M0236-00	36"L	each
F11M0242-00	42"L	each
F11M0248-00	48"L	each
F11M0254-00	54"L	each
F11M0260-00	60"L	each
F11M0266-00	66"L	each
F11M0272-00	72"L	each

Above Countertop Wall Suspension System

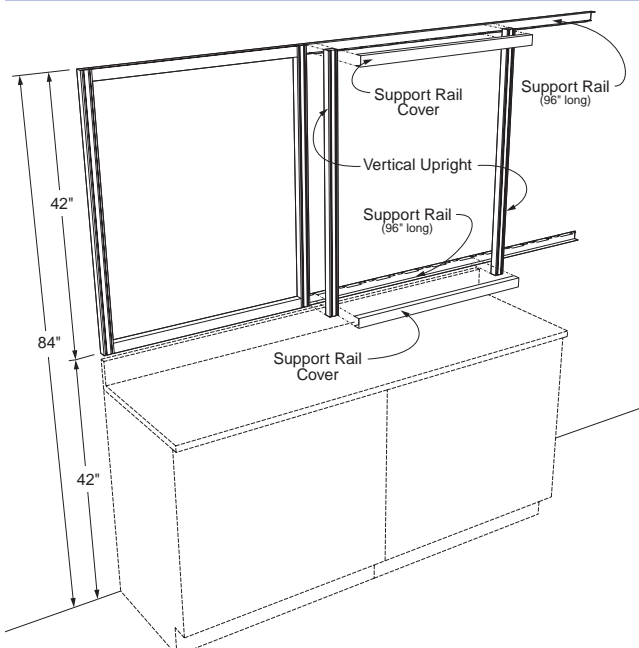

Vertical Upright

F10M0242-00	42"H	pair
--------------------	------	------

Support Rail

F11M0196-00	96"L	each
--------------------	------	------

Support Rail Covers

F11M0324-00	24"L	pair
F11M0330-00	30"L	pair
F11M0336-00	36"L	pair
F11M0342-00	42"L	pair
F11M0348-00	48"L	pair
F11M0354-00	54"L	pair
F11M0360-00	60"L	pair
F11M0366-00	66"L	pair
F11M0372-00	72"L	pair

Wall Shelving Assemblies

Specifications:

Adjustable Wall Shelf Assemblies consist of a pair of 11 gauge steel Shelf Brackets and a Shelf. The Shelf Bracket engages the inner slot of the double slotted Wall Vertical Upright and is adjustable on 1" centers. Shelves are available in Painted Steel, Oak or Maple veneer plywood, or Phenolic Resin.

Painted Steel Shelves – 1" thick, formed from 16 gauge cold rolled steel.

Oak & Maple Shelves – 1" thick hardwood plywood with matching veneer on all exposed surfaces.

Phenolic Resin – 1" thick phenolic resin.

Adjustable Wall Shelf Assemblies

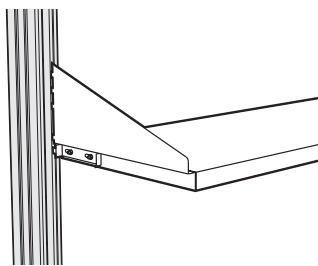
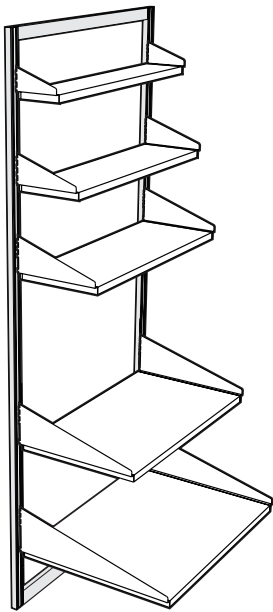

	Length	Painted Steel	Plastic Laminate	Phenolic Resin
6" DEEP SHELF 6" Deep Bracket	24"	F21M0624-00	F21P0624-00	F21T0624-00
	30"	F21M0630-00	F21P0630-00	F21T0630-00
	36"	F21M0636-00	F21P0636-00	F21T0636-00
	42"	F21M0642-00	F21P0642-00	F21T0642-00
	48"	F21M0648-00	F21P0648-00	F21T0648-00
	54"	F21M0654-00		
	60"	F21M0660-00		
	66"	F21M0666-00		
	72"	F21M0672-00		
9" DEEP SHELF 9" Deep Bracket	24"	F21M0924-00	F21P0924-00	F21T0924-00
	30"	F21M0930-00	F21P0930-00	F21T0930-00
	36"	F21M0936-00	F21P0936-00	F21T0936-00
	42"	F21M0942-00	F21P0942-00	F21T0942-00
	48"	F21M0948-00	F21P0948-00	F21T0948-00
	54"	F21M0954-00		
	60"	F21M0960-00		
	66"	F21M0966-00		
	72"	F21M0972-00		
12" DEEP SHELF 12" Deep Bracket	24"	F21M1224-00	F21P1224-00	F21T1224-00
	30"	F21M1230-00	F21P1230-00	F21T1230-00
	36"	F21M1236-00	F21P1236-00	F21T1236-00
	42"	F21M1242-00	F21P1242-00	F21T1242-00
	48"	F21M1248-00	F21P1248-00	F21T1248-00
	54"	F21M1254-00		
	60"	F21M1260-00		
	66"	F21M1266-00		
	72"	F21M1272-00		
18" DEEP SHELF 18" Deep Bracket	24"	F21M1824-00	F21P1824-00	F21T1824-00
	30"	F21M1830-00	F21P1830-00	F21T1830-00
	36"	F21M1836-00	F21P1836-00	F21T1836-00
	42"	F21M1842-00	F21P1842-00	F21T1842-00
	48"	F21M1848-00	F21P1848-00	F21T1848-00
	54"	F21M1854-00		
	60"	F21M1860-00		
24" DEEP SHELF 24" Deep Bracket	24"	F21M2424-00	F21P2424-00	F21T2424-00
	30"	F21M2430-00	F21P2430-00	F21T2430-00
	36"	F21M2436-00	F21P2436-00	F21T2436-00
	42"	F21M2442-00	F21P2442-00	F21T2442-00
	48"	F21M2448-00	F21P2448-00	F21T2448-00
	54"	F21M2454-00		
	60"	F21M2460-00		

Optional Shelf Locking Tab

Sliding tab mounted on Shelf Bracket locks Shelf into upright to keep it from being accidentally removed.

To specify, add an **K** to the end of the Shelf Assembly part number. Example: **F21M1236-00K**

See Kewaunee's Alpha System catalog for more shelving options

Technical Information

Wall Cabinet Sectional Views

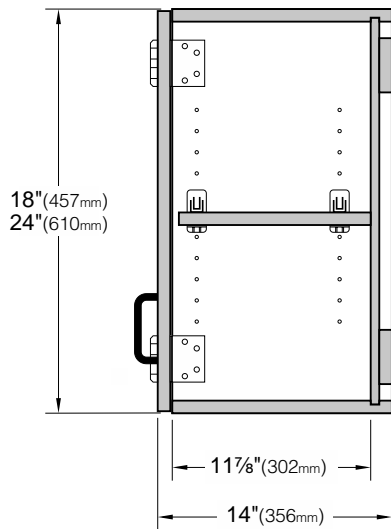

18" & 24" High Wall Cabinets

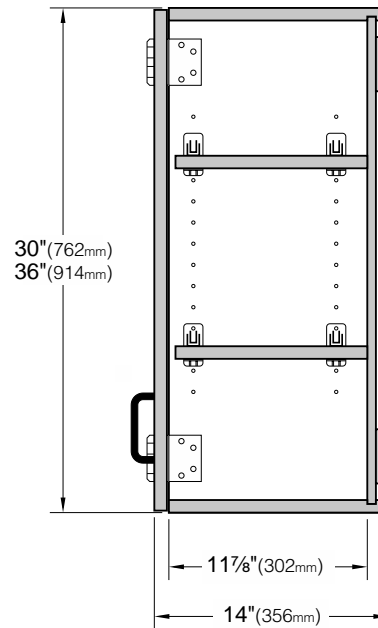

30" & 36" High Wall Cabinets

Base Cabinet Sectional Views

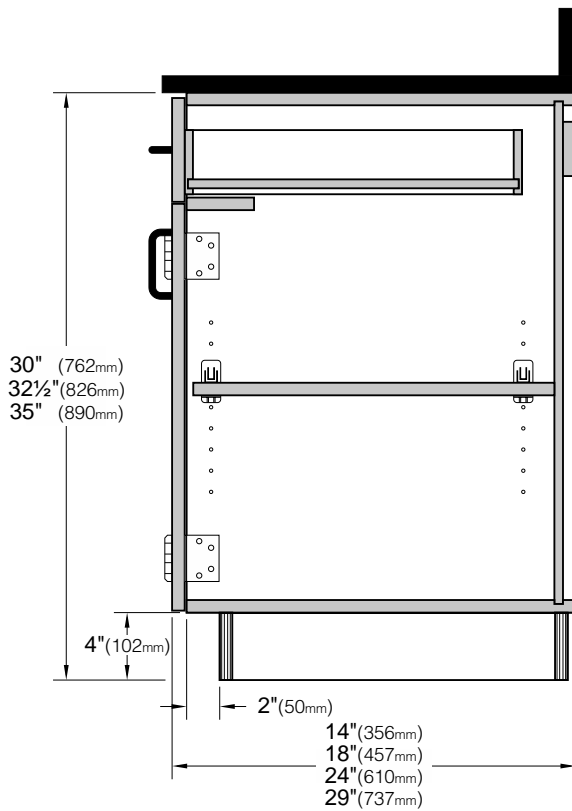

Base Cabinet

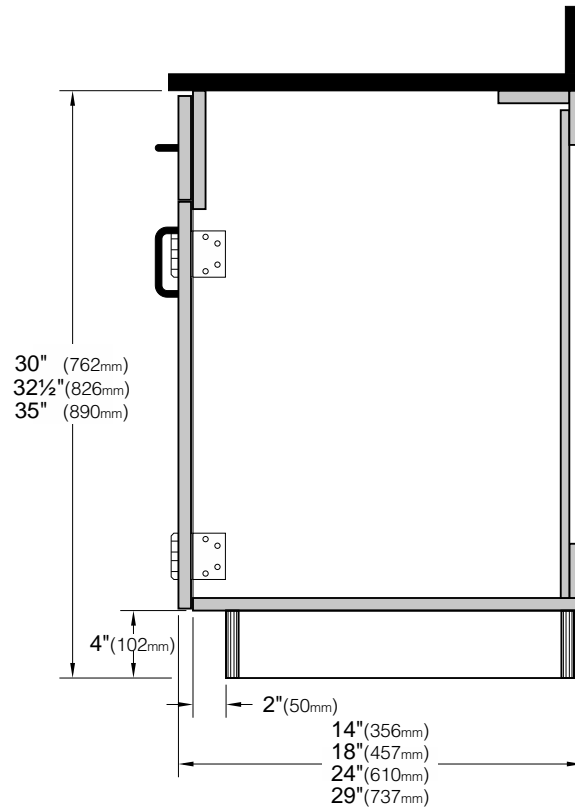

Sink Cabinet

Technical Information

Tall Cabinet Sectional Views

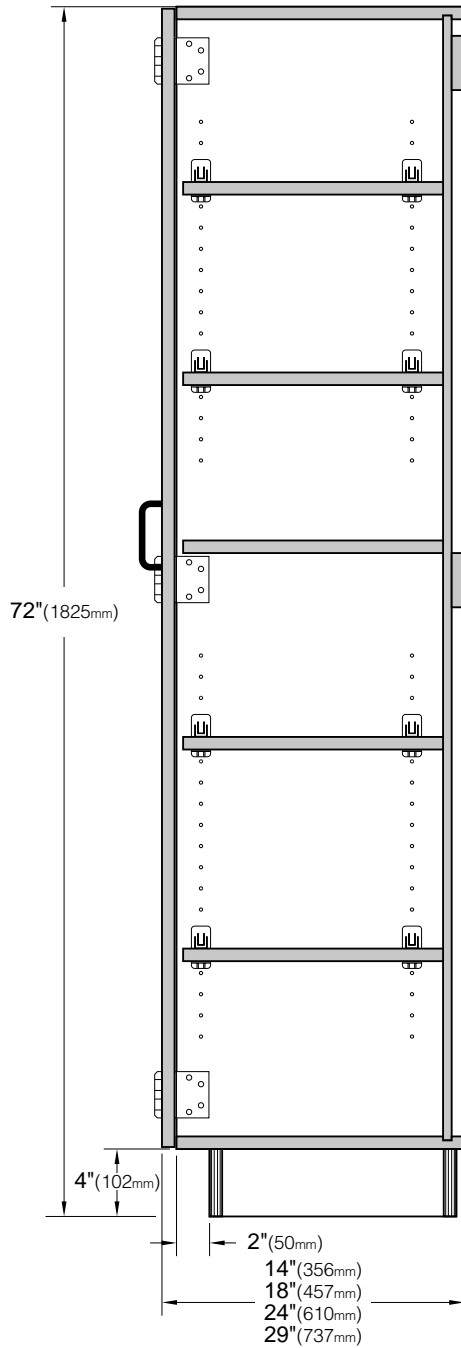

72" High Tall Cabinets

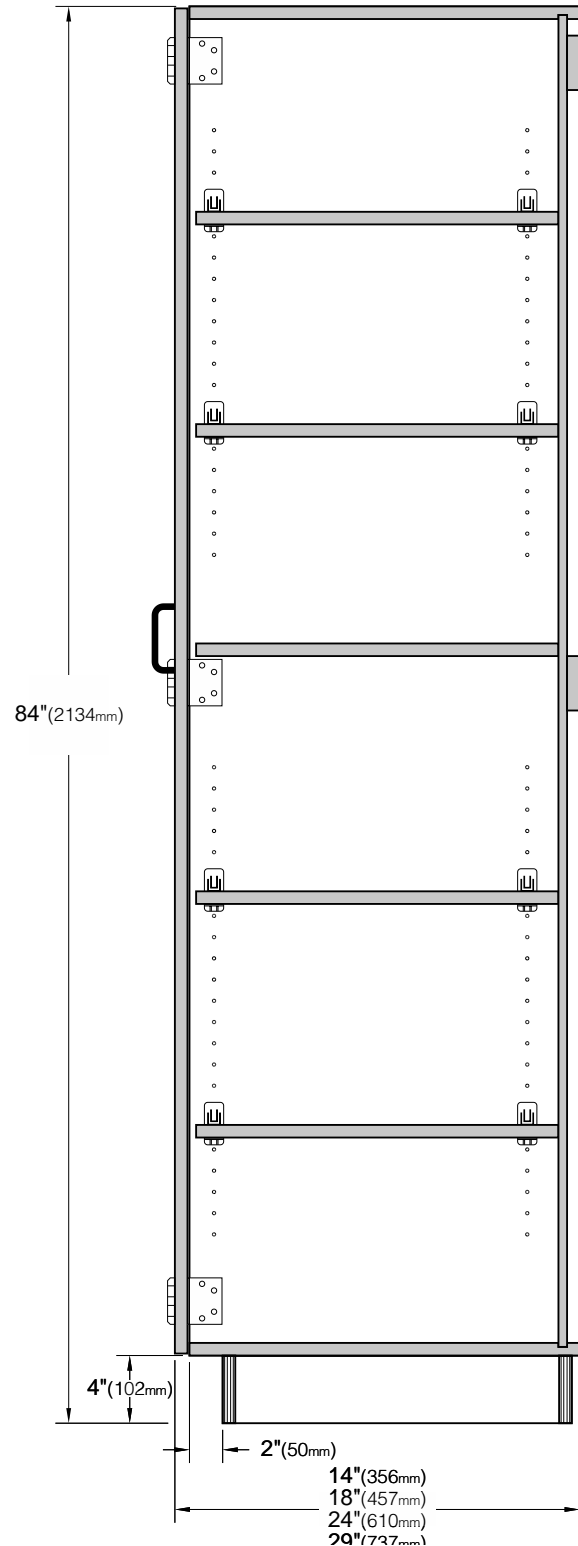

84" High Tall Cabinets

Alphabetical Index

A	Aprons	8	P	Phenolic Resin Shelving	59
B	Base Cabinets	9		Plastic Laminate Shelving	59
	Combination Units	25		Plastic Laminate Work Tops	56
	Construction Details	7	S	Section Views	60
	Door Units	12		Base Cabinets	60
	Drawer Units	17		Tall Cabinets	61
	Open Units	9		Wall Cabinets	60
	Section View	60		Shelving	58
	Sink Units	30		Assembly	58
C	Cabinet Options Check List	4		Plastic Laminate	59
	Check Lists	4		Phenolic Resin	59
	Composite Resin Work Tops	56		Steel	59
D	Drawer Dimensions	6		Stainless Steel Work Tops	56
F	Fillers	55		Steel Shelving	59
H	Hardware Options	3	T	Tall Cabinets	45
	Hardwood Work Tops	56		Construction Details	44
	High-pressure Laminate Work Tops	56		Cupboard Cabinets	48
K	Kemresin Work Tops	56		Open Cabinets	45
M	Maple Work Tops	56		Section View	61
O	Oak Work Tops	56		Trim	55
			W	Wall Cabinets	34
				Construction Details	33
				Cupboard Cabinets	37
				Open Cabinets	34
				Section View	60
				Wall Shelving	58
				Work Tops	56
				Worksurface Options Check List	5

Numerical Index

Part Number	Page	Part Number	Page
A1100	- A1202.....8	T0000	- T000645
C0000	- C0010.....9	T0008	- T001446
C0012	- C0022.....10	T0016	- T002247
C0024	- C0900.....10	T0024	- T110948
C1100	- C1105.....12	T1116	- T111949
C1106	- C1206.....13	T1120	- T112350
C1208	- C1218.....14	T1208	- T121851
C1220	- C1804.....15	T1220	- T122652
C1805	- C3202.....16	T1228	- T220853
		T2212	-54
D1104	- D2108.....17	W0000	- W001034
D2200	- D3104.....18	W0012	- W002235
D3106	- D3116.....19	W0024	- W080036
D3118	- D3208.....20	W1100	- W120237
D4100	- D4110.....21	W1204	- W121238
D4112	- D4202.....22	W1214	- W180239
D4204	- D5106.....23	W1803	- W180840
D5200	- D6102.....24	W1809	- W220241
E2100	- E220425	W2206	- W420242
E2206	- E320026	W4206	- W620243
E3201	- E420027	Z3100	- Z310455
E4201	- E520028		
E5201	- E520329		
F10M0242-0058		
F10M0279-0058		
F11M0196-0058		
F11M0224-00	- F11M0372-0058		
F21M0624-00	- F21M2460-0059		
F21P0624-00	- F21P2448-0059		
F21T0624-00	- F21T2448-0059		
FILB	- FILW55		
S1100	- S110530		
S1106	- S120631		
S1208	- S520032		

Typical Installations



Typical Installations





SPEKTRUM Health Care



SPEKTRUM Education



SPEKTRUM Laboratory



SPEKTRUM Green



SPEKTRUM Value



PO Box 1842 • Statesville, NC 28687-1842
Phone: (704) 873-7202 • Fax: (800) 932-3296
Email: kscmarketing@kewaunee.com
Web Site: www.kewaunee.com

