

12" Island Structural Modules

Features:

- 12" Island Structural Modules provide support for a wide combination of accessories, including:
 - adjustable worksurface frames
 - adjustable tables
 - hanging cabinetry - upper and lower
 - floor mounted cabinetry
 - adjustable shelving
 - lighting
 - electrical and plumbing raceway
 - service drops
 - tack boards and marker boards
 - pegboards
- 12" Island Structural Modules provide 6" of service space and are built to receive standard pipe hangers for ease of installing service piping and electrical conduit.
- System design allows shelving to be suspended both above and below the worksurface.
- Easy and positive structural alignment and attachment to adjacent modules.
- Available with easy to remove access panels. May be ordered without access panels for use with floor mounted base cabinets.

SEFA 10 | Class 5 – Configuration 2 – Category 2

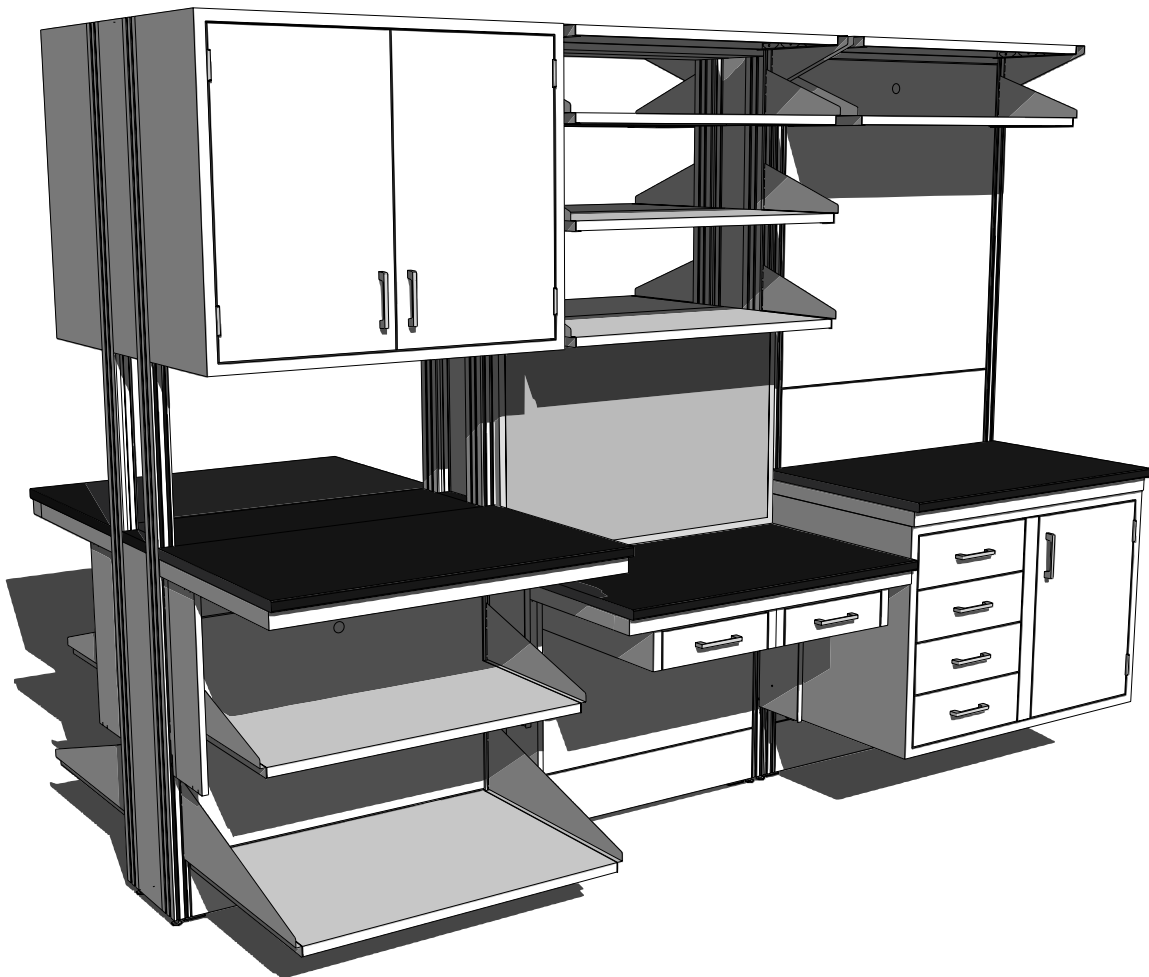

12" Island Structural Modules

Specifications:

Island Modules are 37" high, with Upper Carriers, 84" high. Both are 12" deep and available in lengths shown.

Modules are available with or without Access Panels. Order without when used with floor mounted base cabinets.

Each module is furnished with hardware for attaching adjacent modules.

Module Ledge must be ordered separately.

12" Deep Island Module – 37" High

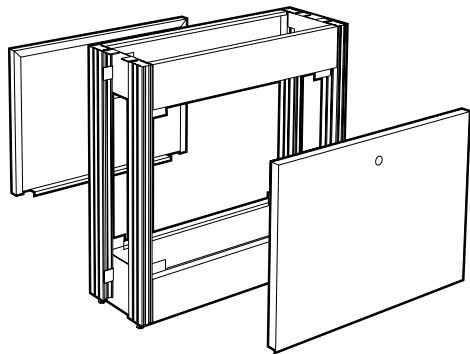

Length	with Access Panels	without Access Panels
24"	F06M3724-00	F06-3724-00
30"	F06M3730-00	F06-3730-00
36"	F06M3736-00	F06-3736-00
42"	F06M3742-00	F06-3742-00
48"	F06M3748-00 *	F06-3748-00
54"	F06M3754-00 *	F06-3754-00
60"	F06M3760-00 *	F06-3760-00
66"	F06M3766-00 *	F06-3766-00
72"	F06M3772-00 *	F06-3772-00

* Modules 48" long and over are provided with two half-length Access Panels.

12" Deep Island Module with Upper Carrier – 84" High

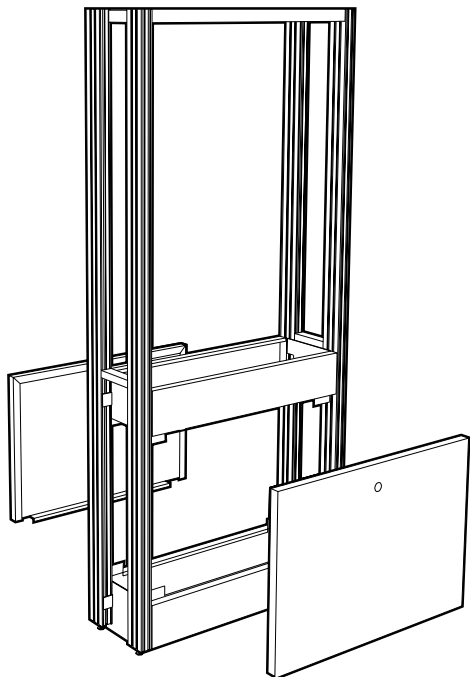

Length	with Access Panels	without Access Panels
24"	F36M3724-00	F36-3724-00
30"	F36M3730-00	F36-3730-00
36"	F36M3736-00	F36-3736-00
42"	F36M3742-00	F36-3742-00
48"	F36M3748-00 *	F36-3748-00
54"	F36M3754-00 *	F36-3754-00
60"	F36M3760-00 *	F36-3760-00
66"	F36M3766-00 *	F36-3766-00
72"	F36M3772-00 *	F36-3772-00

* Modules 48" long and over are provided with two half-length Access Panels.

12" Island Structural Modules

Specifications:

Service Riser Island Modules are 47" high, with Upper Carrier, 84" high. Both are 12" deep and in lengths shown.

Modules are available with or without Access Panels. Order without when used with floor mounted base cabinets.

Each module is furnished with hardware for attaching adjacent modules.

Module Ledge must be ordered separately.

12" Deep Service Riser Island Module – 47" High

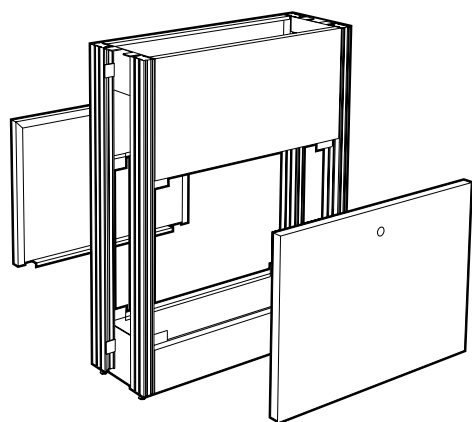

Length	with Access Panels	without Access Panels
24"	F06M4724-00	F06-4724-00
30"	F06M4730-00	F06-4730-00
36"	F06M4736-00	F06-4736-00
42"	F06M4742-00	F06-4742-00
48"	F06M4748-00 *	F06-4748-00
54"	F06M4754-00 *	F06-4754-00
60"	F06M4760-00 *	F06-4760-00
66"	F06M4766-00 *	F06-4766-00
72"	F06M4772-00 *	F06-4772-00

* Modules 48" long and over are provided with two half-length Access Panels.

12" Deep Service Riser Island Module with Upper Carrier – 84" High

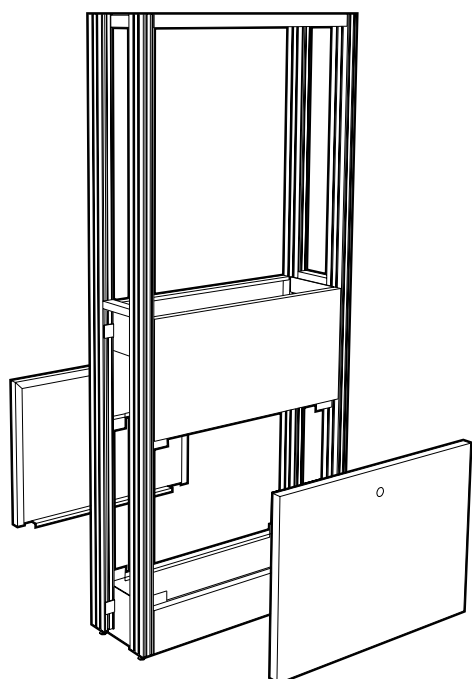

Length	with Access Panels	without Access Panels
24"	F36M4724-00	F36-4724-00
30"	F36M4730-00	F36-4730-00
36"	F36M4736-00	F36-4736-00
42"	F36M4742-00	F36-4742-00
48"	F36M4748-00 *	F36-4748-00
54"	F36M4754-00 *	F36-4754-00
60"	F36M4760-00 *	F36-4760-00
66"	F36M4766-00 *	F36-4766-00
72"	F36M4772-00 *	F36-4772-00

* Modules 48" long and over are provided with two half-length Access Panels.

12" Island Structural Modules

Specifications:

Island Modules are 37" high, with Upper Carriers, 84" high. Both are 12" deep and available in lengths shown.

Modules are available with or without Access Panels. Order without when used with floor mounted base cabinets.

24" and 30" long modules have two single-gang electric box cutouts, all other sizes have three.

Each module is furnished with hardware for attaching adjacent modules.

Module Ledge must be ordered separately.

12" Deep Standard Island Module with Electric Cutouts – 37" High

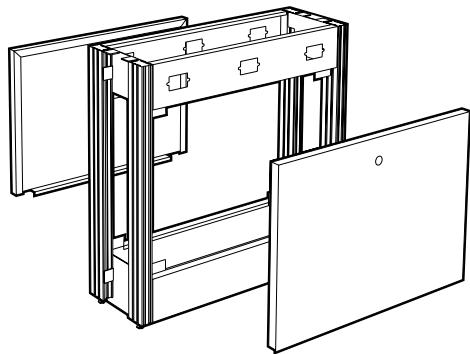

Length	with Access Panels	without Access Panels
24"	F06M3724-E0	F06-3724-E0
30"	F06M3730-E0	F06-3730-E0
36"	F06M3736-E0	F06-3736-E0
42"	F06M3742-E0	F06-3742-E0
48"	F06M3748-E0 *	F06-3748-E0
54"	F06M3754-E0 *	F06-3754-E0
60"	F06M3760-E0 *	F06-3760-E0
66"	F06M3766-E0 *	F06-3766-E0
72"	F06M3772-E0 *	F06-3772-E0

* Modules 48" long and over are provided with two half-length Access Panels.

12" Deep Standard Island Module with Electric Cutouts & Upper Carrier – 84" High

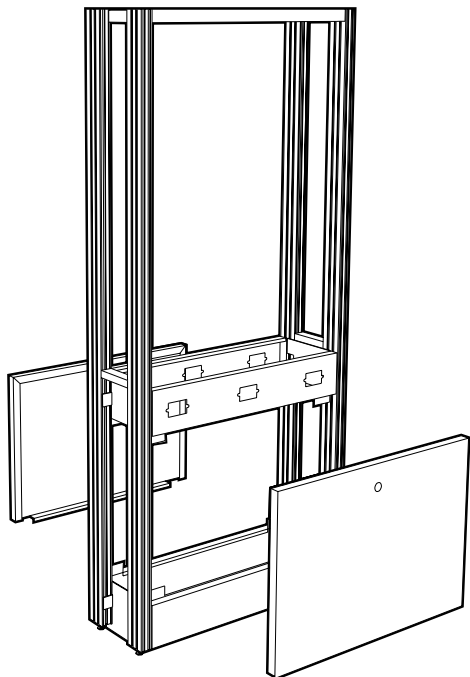

Length	with Access Panels	without Access Panels
24"	F36M3724-E0	F36-3724-E0
30"	F36M3730-E0	F36-3730-E0
36"	F36M3736-E0	F36-3736-E0
42"	F36M3742-E0	F36-3742-E0
48"	F36M3748-E0 *	F36-3748-E0
54"	F36M3754-E0 *	F36-3754-E0
60"	F36M3760-E0 *	F36-3760-E0
66"	F36M3766-E0 *	F36-3766-E0
72"	F36M3772-E0 *	F36-3772-E0

* Modules 48" long and over are provided with two half-length Access Panels.

12" Island Structural Modules

Specifications:

Service Riser Island Modules are 47" high, with Upper Carrier, 84" high. Both are 12" deep and in lengths shown.

Modules are available with or without Access Panels. Order without when used with floor mounted base cabinets.

24" and 30" long modules have two single-gang electric box cutouts, all other sizes have three.

Each module is furnished with hardware for attaching adjacent modules.

Module Ledge must be ordered separately.

12" Deep Service Riser Island Module with Electric Cutouts – 47" High

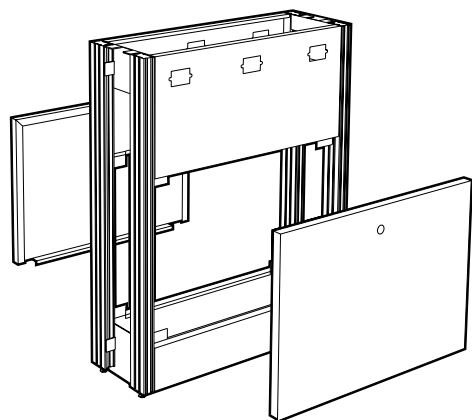

Length	with Access Panels	without Access Panels
24"	F06M4724-E0	F06-4724-E0
30"	F06M4730-E0	F06-4730-E0
36"	F06M4736-E0	F06-4736-E0
42"	F06M4742-E0	F06-4742-E0
48"	F06M4748-E0 *	F06-4748-E0
54"	F06M4754-E0 *	F06-4754-E0
60"	F06M4760-E0 *	F06-4760-E0
66"	F06M4766-E0 *	F06-4766-E0
72"	F06M4772-E0 *	F06-4772-E0

* Modules 48" long and over are provided with two half-length Access Panels.

12" Deep Service Riser Island Module with Electric Cutouts & Upper Carrier – 84" High

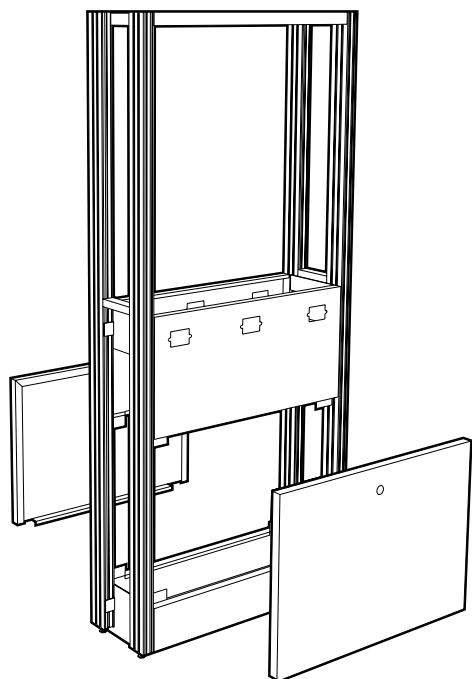

Length	with Access Panels	without Access Panels
24"	F36M4724-E0	F36-4724-E0
30"	F36M4730-E0	F36-4730-E0
36"	F36M4736-E0	F36-4736-E0
42"	F36M4742-E0	F36-4742-E0
48"	F36M4748-E0 *	F36-4748-E0
54"	F36M4754-E0 *	F36-4754-E0
60"	F36M4760-E0 *	F36-4760-E0
66"	F36M4766-E0 *	F36-4766-E0
72"	F36M4772-E0 *	F36-4772-E0

* Modules 48" long and over are provided with two half-length Access Panels.

12" Island Structural Modules

Specifications:

Island Modules with Paneled Upper Carrier are the same as standard Island Modules; except, they are furnished with easy to remove panels to close off the area between the upper carrier uprights. They may be used as a service drop, to hide piping or tubing, or as a room divider.

When ordered with electric cutouts, 24" and 30" long modules have two single-gang electric box cutouts, all other sizes have three.

Each module furnished with hardware for attaching adjacent modules.

Module Ledge is not required.

12" Deep Standard Island Module with Paneled Upper Carrier – 84" High

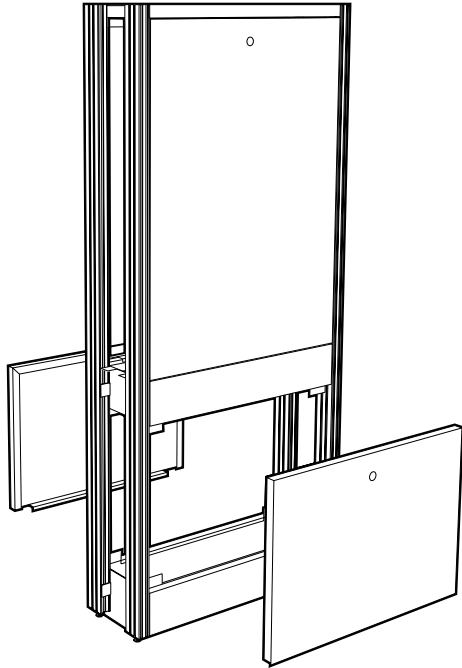

Length	with Lower Access Panels	without Lower Access Panels
24"	F37M3724-00	F37-3724-00
30"	F37M3730-00	F37-3730-00
36"	F37M3736-00	F37-3736-00
42"	F37M3742-00	F37-3742-00
48"	F37M3748-00 *	F37-3748-00 *
54"	F37M3754-00 *	F37-3754-00 *
60"	F37M3760-00 *	F37-3760-00 *
66"	F37M3766-00 *	F37-3766-00 *
72"	F37M3772-00 *	F37-3772-00 *

* Modules 48" long and over are provided with half-length removable panels.

12" Deep Standard Island Module with Electric Cutouts & Paneled Upper Carrier – 84" High

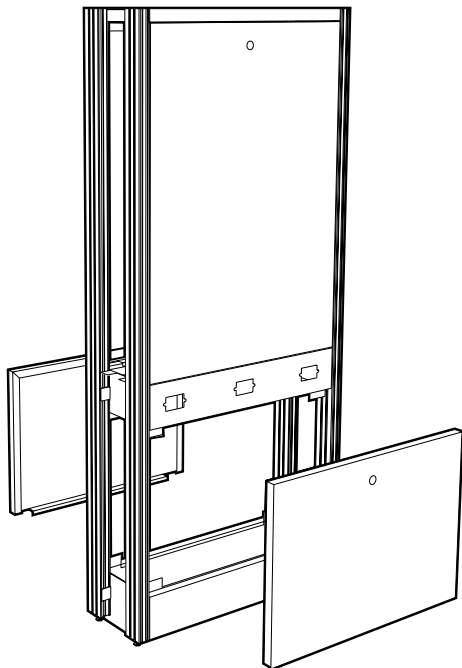

Length	with Lower Access Panels	without Lower Access Panels
24"	F37M3724-E0	F37-3724-E0
30"	F37M3730-E0	F37-3730-E0
36"	F37M3736-E0	F37-3736-E0
42"	F37M3742-E0	F37-3742-E0
48"	F37M3748-E0 *	F37-3748-E0 *
54"	F37M3754-E0 *	F37-3754-E0 *
60"	F37M3760-E0 *	F37-3760-E0 *
66"	F37M3766-E0 *	F37-3766-E0 *
72"	F37M3772-E0 *	F37-3772-E0 *

* Modules 48" long and over are provided with half-length removable panels.

12" Island Structural Modules

Specifications:

Service Riser Island Modules with Paneled Upper Carrier are the same as standard Service Riser Island Modules; except, they are furnished with easy to remove panels to close off the area between the upper carrier uprights. They may be used as a service drop, to hide piping or tubing, or as a room divider.

When ordered with electric cutouts, 24" and 30" long modules have two single-gang electric box cutouts, all other sizes have three.

Each module furnished with hardware for attaching to adjacent modules.

Module Ledge is not required.

12" Deep Service Riser Island Module with Paneled Upper Carrier – 84" High

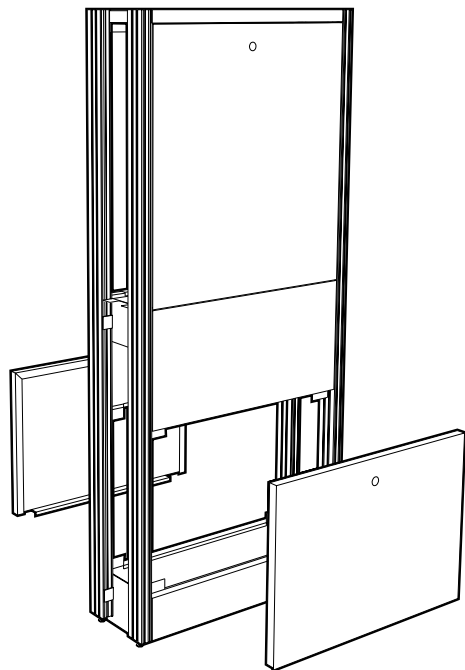

Length	with Lower Access Panels	without Lower Access Panels
24"	F37M4724-00	F37-4724-00
30"	F37M4730-00	F37-4730-00
36"	F37M4736-00	F37-4736-00
42"	F37M4742-00	F37-4742-00
48"	F37M4748-00 *	F37-4748-00 *
54"	F37M4754-00 *	F37-4754-00 *
60"	F37M4760-00 *	F37-4760-00 *
66"	F37M4766-00 *	F37-4766-00 *
72"	F37M4772-00 *	F37-4772-00 *

* Modules 48" long and over are provided with half-length removable panels.

12" Deep Service Riser Island Module with Electric Cutouts & Paneled Upper Carrier – 84" High

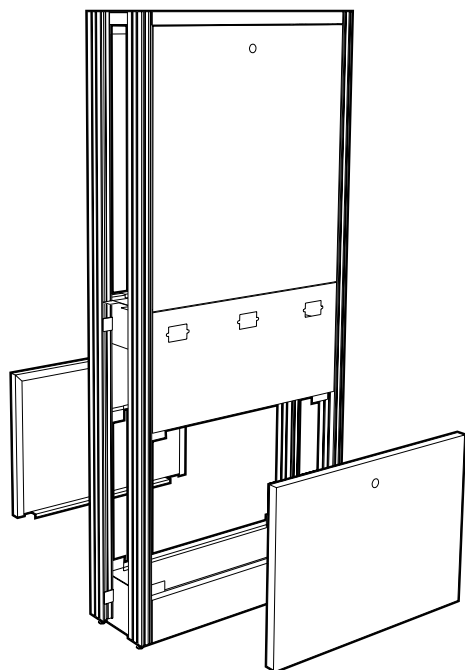

Length	with Lower Access Panels	without Lower Access Panels
24"	F37M4724-E0	F37-4724-E0
30"	F37M4730-E0	F37-4730-E0
36"	F37M4736-E0	F37-4736-E0
42"	F37M4742-E0	F37-4742-E0
48"	F37M4748-E0	F37-4748-E0
54"	F37M4754-E0 *	F37-4754-E0 *
60"	F37M4760-E0 *	F37-4760-E0 *
66"	F37M4766-E0 *	F37-4766-E0 *
72"	F37M4772-E0 *	F37-4772-E0 *

* Modules 48" long and over are provided with half-length removable panels.

Service Tunnels & Wire Raceways

Horizontal Service Tunnel

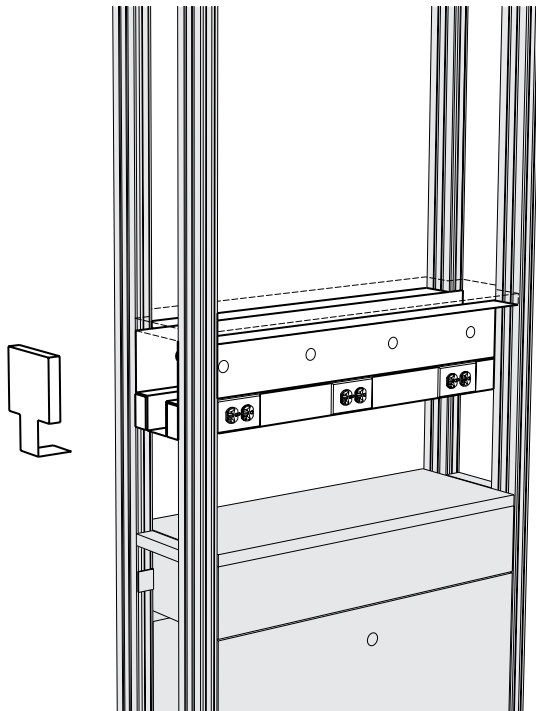

Length	Part Number	Duplex Outlets
24"	F44M0924-00	4
30"	F44M0930-00	4
36"	F44M0936-00	6
42"	F44M0942-00	6
48"	F44M0948-00	6
54"	F44M0954-00	6
60"	F44M0960-00	6
66"	F44M0966-00	6
72"	F44M0972-00	6
End Cap	F44M0901-00	

The Horizontal Service Tunnel combines a 6" deep by 8" high steel enclosure with two G-3000 wire raceways to form a horizontal tunnel that can handle most laboratory service needs. The enclosure allows service fittings to be mounted on either side or on the bottom while providing a 6" x 5" area to run piping. The wire raceways are provided with either two or three 120 volt AC duplex receptacles on each side. The top is designed to be closed with a Module Core Shelf or by adding Service Tunnel Enclosure Panels.

Horizontal Service Tunnels are for use with 12" Island Module Upper Carriers only.

Module Core Shelf for use with Service Tunnels, Manifolds, and Wire Raceways

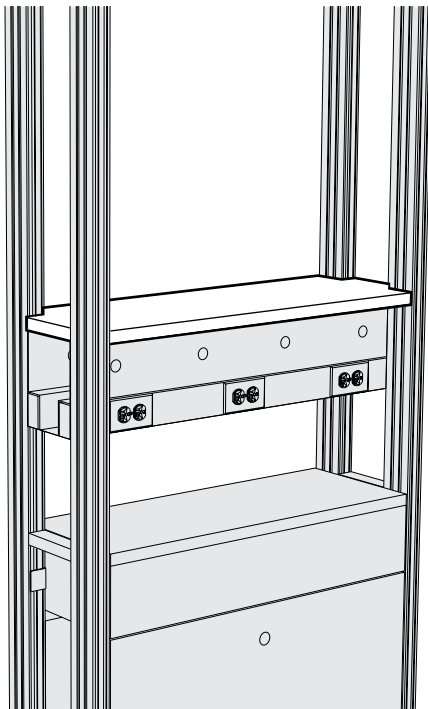

Length	Part Number
24"	F69M1224-00
30"	F69M1230-00
36"	F69M1236-00
42"	F69M1242-00
48"	F69M1248-00
54"	F69M1254-00
60"	F69M1260-00
66"	F69M1266-00
72"	F69M1272-00

The Module Core Shelf may be used to close the top of a Horizontal Service Tunnel or be mounted on top of 18" high Vertical Wire Raceways or Vertical Service Manifolds. They are formed of 16 gauge cold rolled steel and are available in all module lengths.

Vertical Service Distribution

Vertical Wire Raceway

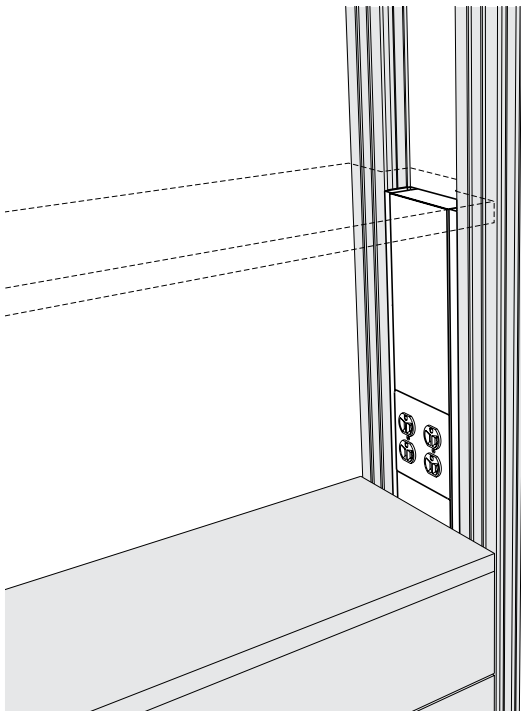

Height	Part Number	Duplex Outlets
18"	F43M0618-00	2
38"	F43M0638-00	4
48"	F43M0648-00	4

The Vertical Wire Raceway uses a G-4000 wire raceway to form an assembly that snaps into place between the uprights of Island Upper Carriers. The raceway is furnished with 120 volt AC duplex receptacles and is designed to connect to power from below.

Vertical Wire Raceways are available in three heights, 18" for use below a Module Core Shelf (as shown), 48" to run full height on a standard Upper Carrier and 38" for use with a Service Riser Upper Carrier.

The raceway may be divided to form two separate compartments to allow running power and communications cabling in the same assembly.

Vertical Wire Raceways are for use with 12" Island Module Upper Carriers only.

Vertical Service Manifold

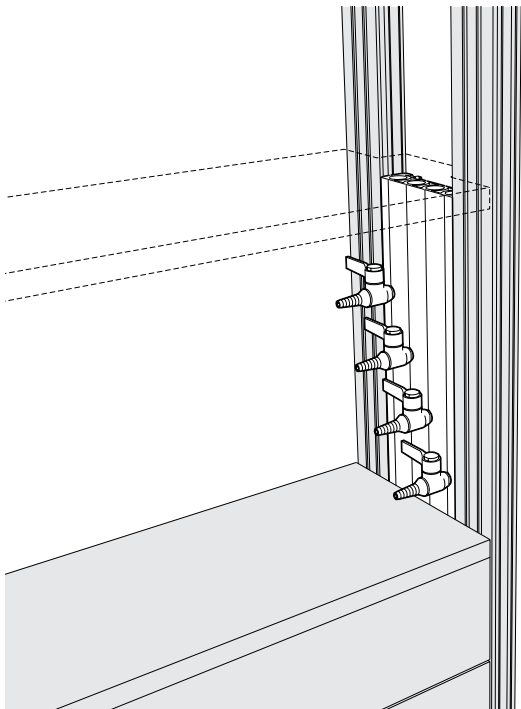

Height	Part Number	Service Outlets
18"	F77M0618-04	4

The Vertical Service Manifold is a one piece extruded aluminum assembly, designed to carry up to four separate services, that slides into place between the uprights of 12" Island Upper Carriers. It is furnished complete with four Laboratory Ball Valves. Services may be piped from either above or below. (Specify services required)

Vertical Service Manifolds are available in other lengths and configurations. Contact your Kewaunee sales representative for further information.

The Vertical Service Manifold is designed for use with 12" Island Module Upper Carriers only.

Enclosure Panels

Upper Carrier Service Tunnel Enclosure Panels

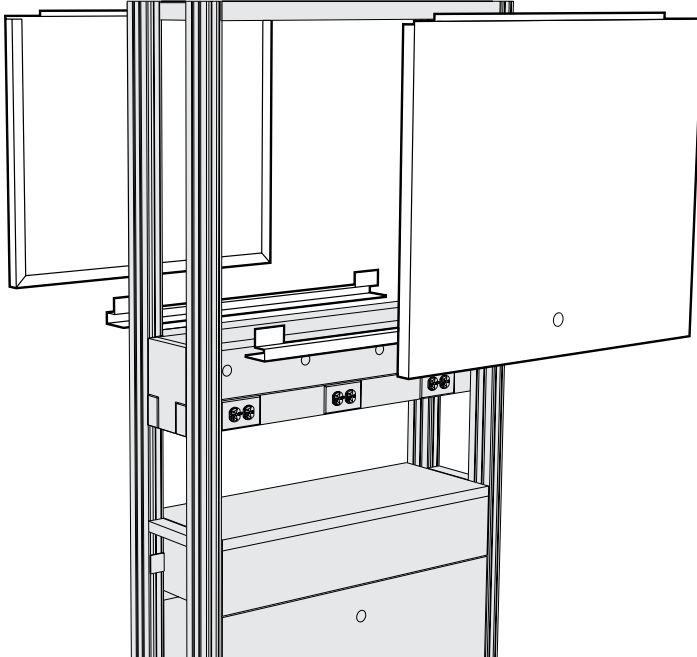

Length	Part Number
24"	F78M3024-00
30"	F78M3030-00
36"	F78M3036-00
42"	F78M3042-00
48"	F78M3048-00
54"	F78M3054-00
60"	F78M3060-00
66"	F78M3066-00
72"	F78M3072-00

Service Tunnel Panels enclose sides of the Upper Carrier above a Horizontal Service Tunnel to hide piping and wiring. Panels are fabricated of cold rolled steel. All necessary hardware is included.

Upper Carrier Enclosure Panels

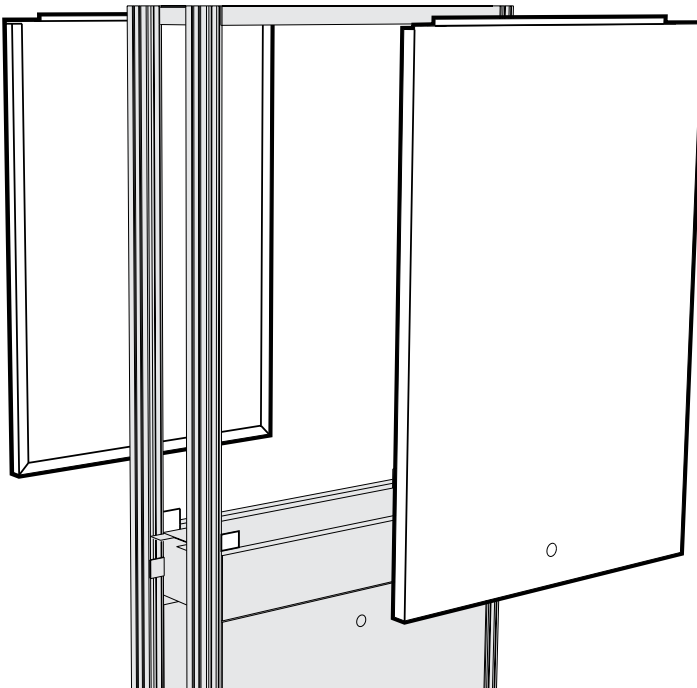

Length	Standard	Service Riser
24"	F79M4824-00	F79M3824-00
30"	F79M4830-00	F79M3830-00
36"	F79M4836-00	F79M3836-00
42"	F79M4842-00	F79M3842-00
48"	F79M4848-00	F79M3848-00
54"	F79M4854-00	F79M3854-00
60"	F79M4860-00	F79M3860-00
66"	F79M4866-00	F79M3866-00
72"	F79M4872-00	F79M3872-00

Upper Carrier Enclosure Panels may be used to convert an open Upper Carrier to Paneled Upper Carrier. Panels are fabricated of cold rolled steel. All necessary hardware is included.

Service Drop

Service Drop Enclosure

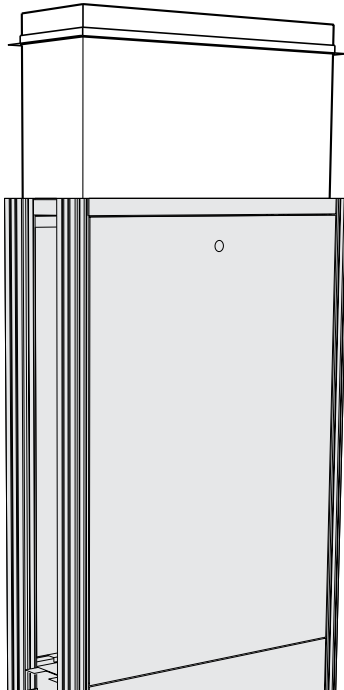

Height	Length	12" Island	6" Island	9" Wall Module
24"	24"	F45M2424-00	F75M2424-00	F46M2424-00
24"	30"	F45M2430-00	F75M2430-00	F46M2430-00
24"	36"	F45M2436-00	F75M2436-00	F46M2436-00
24"	42"	F45M2442-00	F75M2442-00	F46M2442-00
24"	48"	F45M2448-00	F75M2448-00	F46M2448-00
36"	24"	F45M3624-00	F75M3624-00	F46M3624-00
36"	30"	F45M3630-00	F75M3630-00	F46M3630-00
36"	36"	F45M3636-00	F75M3636-00	F46M3636-00
36"	42"	F45M3642-00	F75M3642-00	F46M3642-00
36"	48"	F45M3648-00	F75M3648-00	F46M3648-00
48"	24"	F45M4824-00	F75M4824-00	F46M4824-00
48"	30"	F45M4830-00	F75M4830-00	F46M4830-00
48"	36"	F45M4836-00	F75M4836-00	F46M4836-00
48"	42"	F45M4842-00	F75M4842-00	F46M4842-00
48"	48"	F45M4848-00	F75M4848-00	F46M4848-00

Designed to fit inside the top frame on the Module Upper Carrier and hide piping, conduit and wiring routed from the ceiling. Fabricated of cold rolled steel panels. Furnished complete with angles for ceiling attachment.

Note: Field modification of Module Top Frame is required to accommodate service piping.

12" Island Structural Module Fillers

Specifications:

Island Module End Fillers are designed to close off the end of Island Modules to offer a more finished appearance. They are available in a variety of sizes that may be combined to cover the entire end of the assembly or just a portion.

Island Module End Fillers are provided with all required installation hardware.

12" Deep Island Module End Fillers

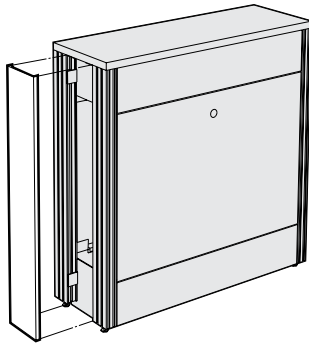

Height	Lower Filler
35"	F00M1236-00
45"	F00M1246-00

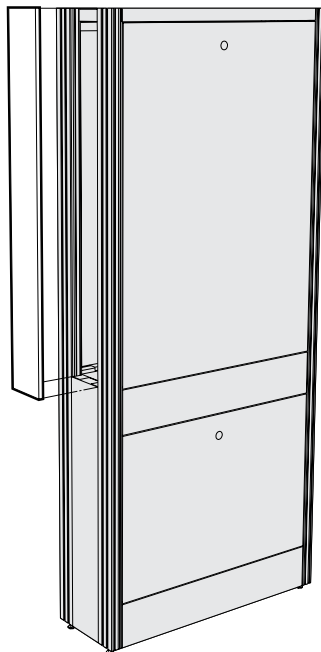

Height	Upper Filler
24"	F00M1224-00
30"	F00M1230-00
38"	F00M1238-00
48"	F00M1248-00

Adjustable Height Worksurface Frames

Specifications:

Adjustable Height Cantilevered Worksurface Frames engage the outer slot of the double slotted Structural Module Upright and adjusts in height on 1" increments. Fabricated from steel channels and an 11 gauge steel hanging bracket.

The Optional Adjustable Height Support Legs may be added to any Worksurface Frame to add strength. Fabricated from aluminum tubing with an adjustable glide at the bottom of the leg, they may be added or removed as required

Worksurface Top must be ordered separately.

Adjustable Height Cantilevered Worksurface Frame – 23¼" Deep

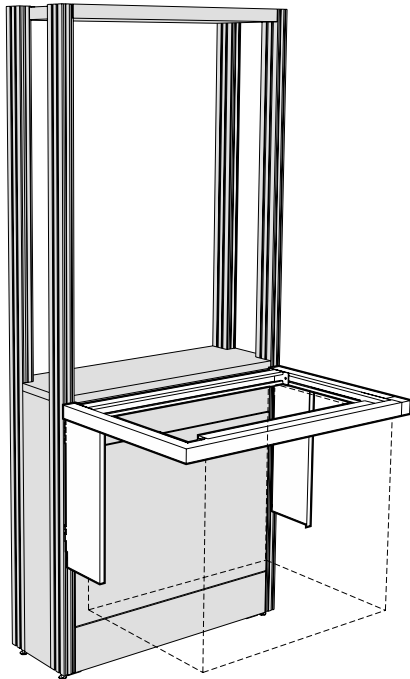

Length	23¼" Deep Frame
24"	F80-2324-00
30"	F80-2330-00
36"	F80-2336-00
42"	F80-2342-00
48"	F80-2348-00
54"	F80-2354-00
60"	F80-2360-00
66"	F80-2366-00
72"	F80-2372-00

Adjustable Height Worksurface Frames

Specifications:

Adjustable Height Cantilevered Worksurface Frames engage the outer slot of the double slotted Structural Module Upright and adjusts in height on 1" increments. Fabricated from steel channels and an 11 gauge steel hanging bracket.

The Optional Adjustable Height Support Legs may be added to any Worksurface Frame to add strength. Fabricated from aluminum tubing with an adjustable glide at the bottom of the leg, they may be added or removed as required.

Worksurface Top must be ordered separately.

Adjustable Height Cantilevered Worksurface Frame – 29¼" Deep

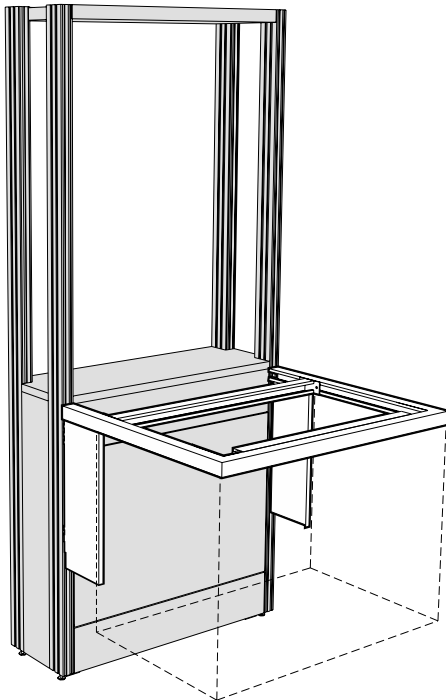

Length	29¼" Deep Frame
24"	F80-2924-00
30"	F80-2930-00
36"	F80-2936-00
42"	F80-2942-00
48"	F80-2948-00
54"	F80-2954-00
60"	F80-2960-00
66"	F80-2966-00
72"	F80-2972-00

Adjustable Height Worksurface Frames

Specifications:

Adjustable Height Cantilevered Corner Worksurface Frame, same as standard Worksurface Frame except designed to be used when two Structural Modules meet to form an inside corner. Frame supports Worksurface Top and can also support a Suspended Cabinet mounted 45 degrees to the module.

The Corner Worksurface Frame Filler may be used to fill the space below the Corner Worksurface Frame when a suspended base cabinet is not used. The filler is fabricated from cold rolled steel and is finished to match the frame.

Worksurface Top must be ordered separately.

Adjustable Height Cantilevered Corner Worksurface Frame

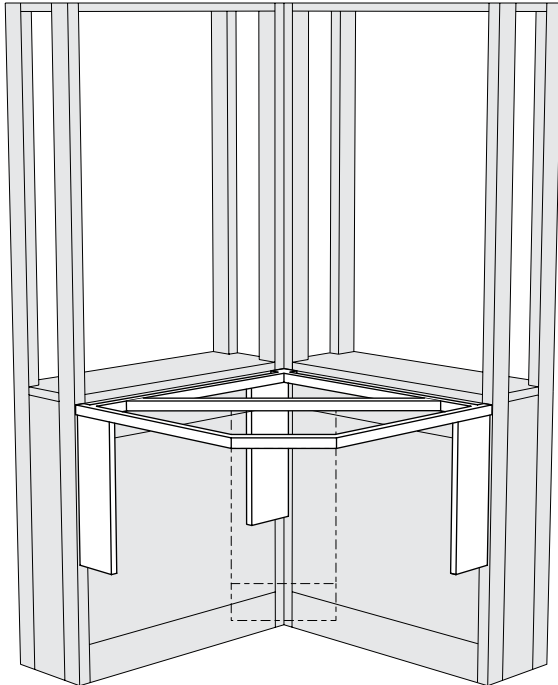

Module Length	23" Deep Frame	Maximum Cabinet Size
36"	F81-2336-00	18" L
42"	F81-2342-00	24" L
48"	F81-2348-00	30" L
Module Length	29" Deep Frame	Maximum Cabinet Size
36"	F81-2936-00	n/a
42"	F81-2942-00	18" L
48"	F81-2948-00	24" L

Corner Worksurface Frame Filler

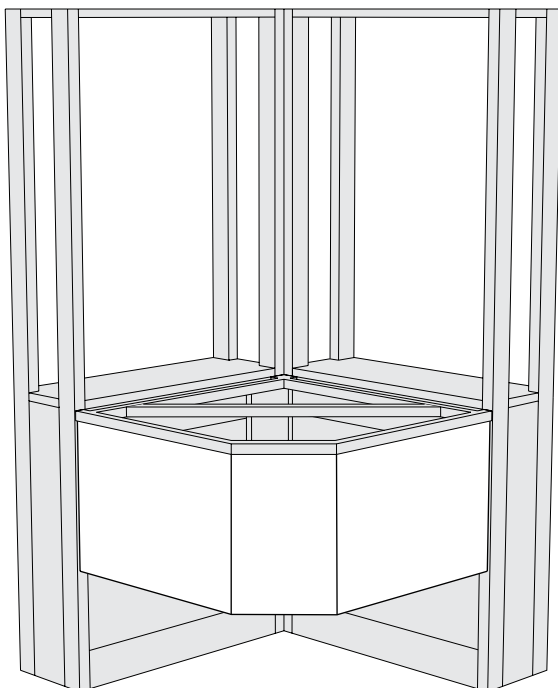

Module Length	23" Deep Frame	29" Deep Frame
36"	F82M2336-00	F82M2936-00
42"	F82M2342-00	F82M2942-00
48"	F82M2348-00	F82M2948-00

Worksurface & Module Tops

Features:

- Module Ledges and Worksurface Tops available in three laboratory proven materials:
 - Kewaunee Kemresin®
 - Phenolic Resin
 - High Pressure Laminate
- Module Ledges and Worksurface Tops available in all Module and Worksurface Frame sizes.
- Modular Worksurface Tops available with 1" wide "Cord Gaps".
- Custom cutout and fixture hole arrangements available.
- Custom Worksurface Top sizes and styles available.

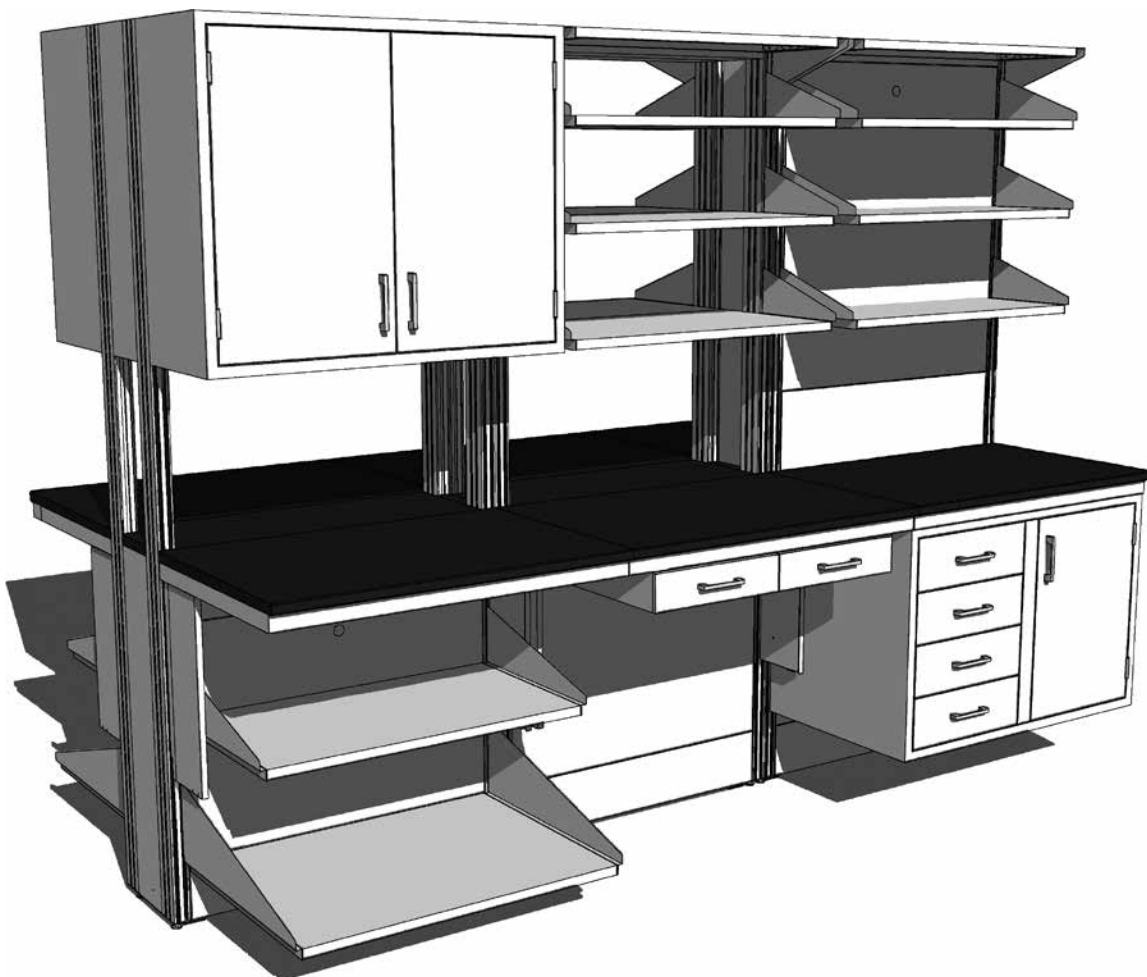

Module Ledges

Specifications:

Module Ledges are required to cover the open top of Wall and Island Structural Modules. They are 1" thick with all edges finished square and are most commonly ordered in the same material and color as the Worksurface Tops, but it is not required.

F92 Module Ledges are designed for use on Modules without Upper Carriers and match the Module length.

F90 Module Ledges are for use on Modules with Upper Carriers, and are 3 1/4" less in length than the Module.

3" Deep Module Ledges for 37" & 47" High Wall Modules

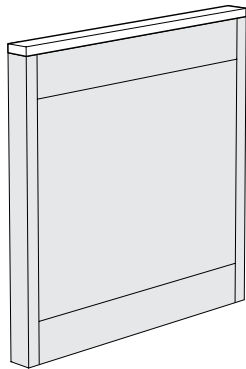

Length	Kemresin®	Phenolic Resin	High Pressure Laminate
24"	F92R0324-00	F92T0324-00	F92P0324-00
30"	F92R0330-00	F92T0330-00	F92P0330-00
36"	F92R0336-00	F92T0336-00	F92P0336-00
42"	F92R0342-00	F92T0342-00	F92P0342-00
48"	F92R0348-00	F92T0348-00	F92P0348-00
54"	F92R0354-00	F92T0354-00	F92P0354-00
60"	F92R0360-00	F92T0360-00	F92P0360-00
66"	F92R0366-00	F92T0366-00	F92P0366-00
72"	F92R0372-00	F92T0372-00	F92P0372-00

3" Deep Module Ledges for 84" High Wall Modules with Upper Carriers

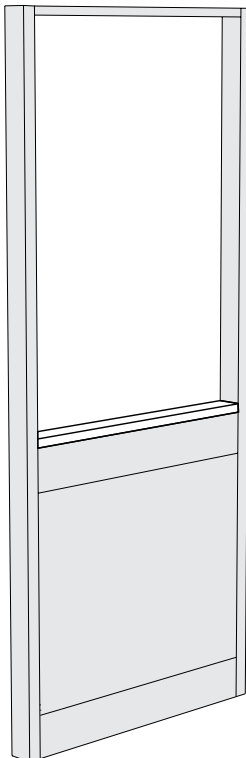

Length	Kemresin®	Phenolic Resin	High Pressure Laminate
24"	F90R0324-00	F90T0324-00	F90P0324-00
30"	F90R0330-00	F90T0330-00	F90P0330-00
36"	F90R0336-00	F90T0336-00	F90P0336-00
42"	F90R0342-00	F90T0342-00	F90P0342-00
48"	F90R0348-00	F90T0348-00	F90P0348-00
54"	F90R0354-00	F90T0354-00	F90P0354-00
60"	F90R0360-00	F90T0360-00	F90P0360-00
66"	F90R0366-00	F90T0366-00	F90P0366-00
72"	F90R0372-00	F90T0372-00	F90P0372-00

Color Option Code

Kemresin

BK = Black **GR** = Grey **PT**=Putty **SL** = Slate

Kemresin is available in four standard colors. To specify Kemresin color, place a dash and the two-letter code at the end of the part number.

Example: F92R0324-00-**BK** for Black

If no color is specified, Kemresin will be furnished in Black.

Phenolic Resin - High Pressure Laminate

Phenolic Resin and High Pressure Laminate is furnished in Black standard.

Module Ledges

Specifications:

Module Ledges are required to cover the open top of Wall and Island Structural Modules. They are 1" thick with all edges finished square and are most commonly ordered in the same material and color as the Worksurface Tops, but it is not required.

F92 Module Ledges are designed for use on Modules without Upper Carriers and match the Module length.

F90 Module Ledges are for use on Modules with Upper Carriers, and are 3 1/4" less in length than the Module.

9" Deep Module Ledges for 37" & 47" High Wall Modules

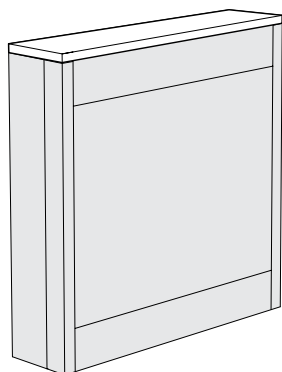

Length	Kemresin®	Phenolic Resin	High Pressure Laminate
24"	F92R0924-00	F92T0924-00	F92P0924-00
30"	F92R0930-00	F92T0930-00	F92P0930-00
36"	F92R0936-00	F92T0936-00	F92P0936-00
42"	F92R0942-00	F92T0942-00	F92P0942-00
48"	F92R0948-00	F92T0948-00	F92P0948-00
54"	F92R0954-00	F92T0954-00	F92P0954-00
60"	F92R0960-00	F92T0960-00	F92P0960-00
66"	F92R0966-00	F92T0966-00	F92P0966-00
72"	F92R0972-00	F92T0972-00	F92P0972-00

9" Deep Module Ledges for 84" High Wall Modules with Upper Carriers

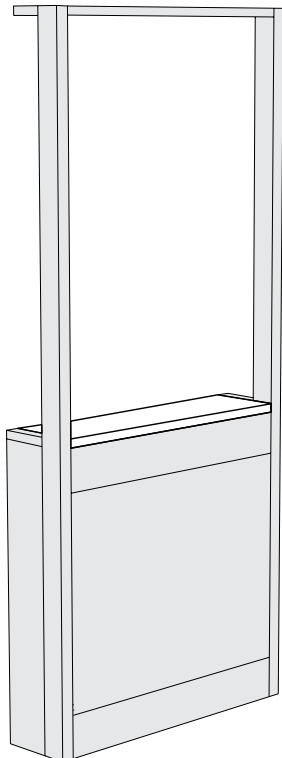

Length	Kemresin®	Phenolic Resin	High Pressure Laminate
24"	F90R0924-00	F90T0924-00	F90P0924-00
30"	F90R0930-00	F90T0930-00	F90P0930-00
36"	F90R0936-00	F90T0936-00	F90P0936-00
42"	F90R0942-00	F90T0942-00	F90P0942-00
48"	F90R0948-00	F90T0948-00	F90P0948-00
54"	F90R0954-00	F90T0954-00	F90P0954-00
60"	F90R0960-00	F90T0960-00	F90P0960-00
66"	F90R0966-00	F90T0966-00	F90P0966-00
72"	F90R0972-00	F90T0972-00	F90P0972-00

Module End Caps

Depth	Kemresin®	Phenolic Resin	High Pressure Laminate
6"	F91R0206-00	F91T0206-00	F91P0206-00

Color Option Code

Kemresin

BK = Black **GR** = Grey **PT** = Putty **SL** = Slate

Kemresin is available in four standard colors. To specify Kemresin color, place a dash and the two-letter code at the end of the part number.

Example: F92R0924-00-**BK** for Black

If no color is specified, Kemresin will be furnished in Black.

Phenolic Resin - High Pressure Laminate

Phenolic Resin and High Pressure Laminate is furnished in Black standard.

Module Ledges

Specifications:

Module Ledges are required to cover the open top of Wall and Island Structural Modules. They are 1" thick with all edges finished square and are most commonly ordered in the same material and color as the Worksurface Tops, but it is not required.

F92 Module Ledges are designed for use on Modules without Upper Carriers and match the Module length.

F90 Module Ledges are for use on Modules with Upper Carriers, and are 3 1/4" less in length than the Module.

12" Deep Module Ledges for 37" & 47" High Island Modules

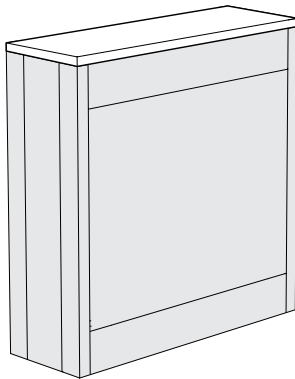

Length	Kemresin®	Phenolic Resin	High Pressure Laminate
24"	F92R1224-00	F92T1224-00	F92P1224-00
30"	F92R1230-00	F92T1230-00	F92P1230-00
36"	F92R1236-00	F92T1236-00	F92P1236-00
42"	F92R1242-00	F92T1242-00	F92P1242-00
48"	F92R1248-00	F92T1248-00	F92P1248-00
54"	F92R1254-00	F92T1254-00	F92P1254-00
60"	F92R1260-00	F92T1260-00	F92P1260-00
66"	F92R1266-00	F92T1266-00	F92P1266-00
72"	F92R1272-00	F92T1272-00	F92P1272-00

12" Deep Module Ledges for 84" High Island Modules with Upper Carriers

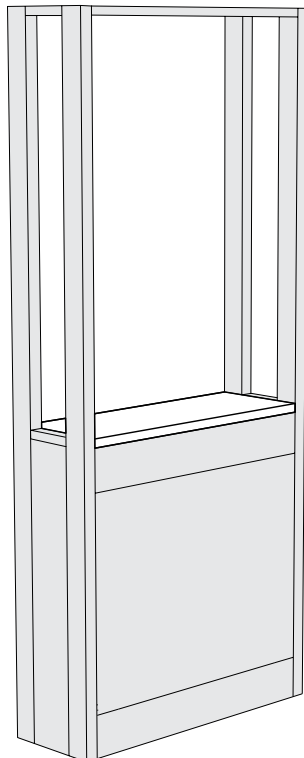

Length	Kemresin®	Phenolic Resin	High Pressure Laminate
24"	F90R1224-00	F90T1224-00	F90P1224-00
30"	F90R1230-00	F90T1230-00	F90P1230-00
36"	F90R1236-00	F90T1236-00	F90P1236-00
42"	F90R1242-00	F90T1242-00	F90P1242-00
48"	F90R1248-00	F90T1248-00	F90P1248-00
54"	F90R1254-00	F90T1254-00	F90P1254-00
60"	F90R1260-00	F90T1260-00	F90P1260-00
66"	F90R1266-00	F90T1266-00	F90P1266-00
72"	F90R1272-00	F90T1272-00	F90P1272-00

Module End Caps

Depth	Kemresin®	Phenolic Resin	High Pressure Laminate
6"	F91R0206-00	F91T0206-00	F91P0206-00

Color Option Code

Kemresin

BK = Black **GR** = Grey **PT**=Putty **SL** = Slate

Kemresin is available in four standard colors. To specify Kemresin color, place a dash and the two-letter code at the end of the part number.

Example: F92R1224-00-**BK** for Black

If no color is specified, Kemresin will be furnished in Black.

Phenolic Resin - High Pressure Laminate

Phenolic Resin and High Pressure Laminate is furnished in Black standard.

Module Ledges

Specifications:

Module Ledges are required to cover the open top of Wall and Island Structural Modules. They are most commonly ordered in the same material and color as the Worksurface Tops, but it is not required.

Module Ledges are 1" thick with all edges finished square. They should be ordered to match the module size on which they are to be used. The actual ledge is

3/4" less in length than the module. The remaining space is covered by the Module End Caps and/or Upper Carrier Uprights which are supplied with the Structural Module.

Additional Module End Caps may be purchased for future reconfiguring, but they are not required.

6" Deep Module Ledge for 37" & 47" High Partition Modules

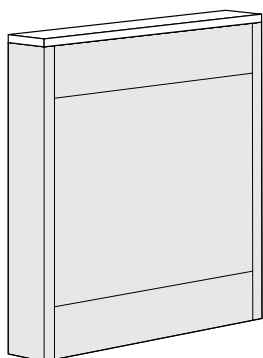

Length	Kemresin®	Phenolic Resin	High Pressure Laminate
24"	F92R0624-00	F92T0624-00	F92P0624-00
30"	F92R0630-00	F92T0630-00	F92P0630-00
36"	F92R0636-00	F92T0636-00	F92P0636-00
42"	F92R0642-00	F92T0642-00	F92P0642-00
48"	F92R0648-00	F92T0648-00	F92P0648-00
54"	F92R0654-00	F92T0654-00	F92P0654-00
60"	F92R0660-00	F92T0660-00	F92P0660-00
66"	F92R0666-00	F92T0666-00	F92P0666-00
72"	F92R0672-00	F92T0672-00	F92P0672-00

6" Deep Module Ledge for 84" High Partition Modules with Upper Carriers

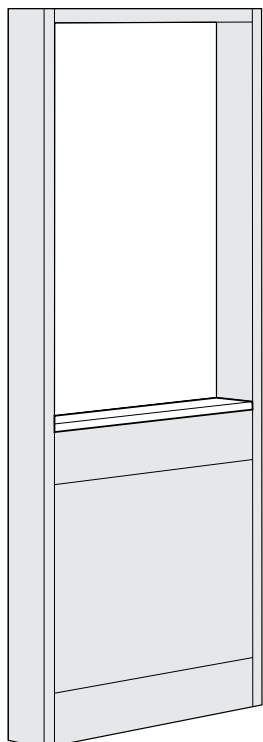

Length	Kemresin®	Phenolic Resin	High Pressure Laminate
24"	F90R0624-00	F90T0624-00	F90P0624-00
30"	F90R0630-00	F90T0630-00	F90P0630-00
36"	F90R0636-00	F90T0636-00	F90P0636-00
42"	F90R0642-00	F90T0642-00	F90P0642-00
48"	F90R0648-00	F90T0648-00	F90P0648-00
54"	F90R0654-00	F90T0654-00	F90P0654-00
60"	F90R0660-00	F90T0660-00	F90P0660-00
66"	F90R0666-00	F90T0666-00	F90P0666-00
72"	F90R0672-00	F90T0672-00	F90P0672-00

Corner & Peninsula Column Module Ledges

Length	Kemresin®	Phenolic Resin	High Pressure Laminate
6" x 6"	F90R0606-00	F90T0606-00	F90P0606-00
9" x 9"	F90R0909-00	F90T0909-00	F90P0909-00
9" x 12"	F90R0912-00	F90T0912-00	F90P0912-00
12" x 12"	F90R1212-00	F90T1212-00	F90P1212-00

Color Option Code

Kemresin

BK = Black **GR** = Grey **PT**=Putty **SL** = Slate

Kemresin is available in four standard colors. To specify Kemresin color, place a dash and the two-letter code at the end of the part number.

Example: F92R0624-00-**BK** for Black

If no color is specified, Kemresin will be furnished in Black.

Phenolic Resin - High Pressure Laminate

Phenolic Resin and High Pressure Laminate is furnished in Black standard.

Worksurface Tops

Specifications:

Worksurface Tops are available in modular sizes to match the length and depth of the Worksurface Frames. They are also available in depths 1" less than the Worksurface Frames to create a "Cord Gap" behind the top. This gap allows cords, cables and flexible tubing to be routed below the worksurface, and out of the way of ongoing work.

Worksurface Tops are 1" thick. Front edges are treated as shown on page 69. All other edges are finished square.

When Worksurface Tops spanning more than one frame are desired or when cutouts are required, custom tops are available. See page 70 and 71 for more information.

Modular Worksurface Tops

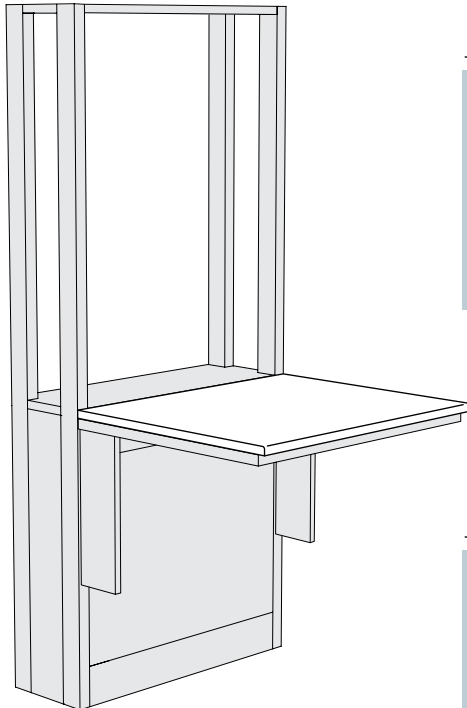

	Length	Kemresin®	Phenolic Resin	High Pressure Laminate
24" DEEP	24"	F95R2424-00	F95T2424-00	F95P2424-00
	30"	F95R2430-00	F95T2430-00	F95P2430-00
	36"	F95R2436-00	F95T2436-00	F95P2436-00
	42"	F95R2442-00	F95T2442-00	F95P2442-00
	48"	F95R2448-00	F95T2448-00	F95P2448-00
	54"	F95R2454-00	F95T2454-00	F95P2454-00
	60"	F95R2460-00	F95T2460-00	F95P2460-00
	66"	F95R2466-00	F95T2466-00	F95P2466-00
	72"	F95R2472-00	F95T2472-00	F95P2472-00

	Length	Kemresin®	Phenolic Resin	High Pressure Laminate
30" DEEP	24"	F95R3024-00	F95T3024-00	F95P3024-00
	30"	F95R3030-00	F95T3030-00	F95P3030-00
	36"	F95R3036-00	F95T3036-00	F95P3036-00
	42"	F95R3042-00	F95T3042-00	F95P3042-00
	48"	F95R3048-00	F95T3048-00	F95P3048-00
	54"	F95R3054-00	F95T3054-00	F95P3054-00
	60"	F95R3060-00	F95T3060-00	F95P3060-00
	66"	F95R3066-00	F95T3066-00	F95P3066-00
	72"	F95R3072-00	F95T3072-00	F95P3072-00

Color Option Code

Kemresin

BK = Black **GR** = Grey **PT**=Putty **SL** = Slate

Kemresin is available in four standard colors. To specify Kemresin color, place a dash and the two-letter code at the end of the part number.

Example: F95R2424-00-**BK** for Black

If no color is specified, Kemresin will be furnished in Black.

Phenolic Resin - High Pressure Laminate

Phenolic Resin and High Pressure Laminate is furnished in Black standard.

Worksurface Tops

Specifications:

Worksurface Tops are available in modular sizes to match the length and depth of the Worksurface Frames. They are also available in depths 1" less than the Worksurface Frames to create a "Cord Gap" behind the top. This gap allows cords, cables and flexible tubing to be routed below the worksurface, and out of the way of ongoing work.

Worksurface Tops are 1" thick. Front edges are treated as shown on page 69. All other edges are finished square.

When Worksurface Tops spanning more than one frame are desired or when cutouts are required, custom tops are available. See page 70 and 71 for more information.

Modular Worksurface Tops with Cord Gap

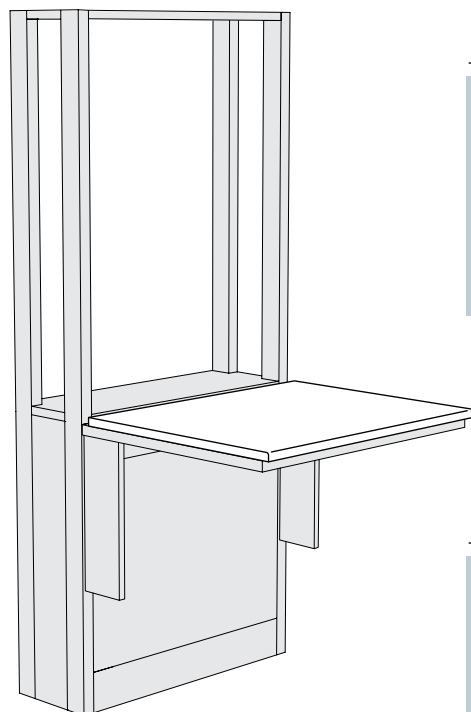

	Length	Kemresin®	Phenolic Resin	High Pressure Laminate
23" DEEP	24"	F95R2324-00	F95T2324-00	F95P2324-00
	30"	F95R2330-00	F95T2330-00	F95P2330-00
	36"	F95R2336-00	F95T2336-00	F95P2336-00
	42"	F95R2342-00	F95T2342-00	F95P2342-00
	48"	F95R2348-00	F95T2348-00	F95P2348-00
	54"	F95R2354-00	F95T2354-00	F95P2354-00
	60"	F95R2360-00	F95T2360-00	F95P2360-00
	66"	F95R2366-00	F95T2366-00	F95P2366-00
	72"	F95R2372-00	F95T2372-00	F95P2372-00

	Length	Kemresin®	Phenolic Resin	High Pressure Laminate
29" DEEP	24"	F95R2924-00	F95T2924-00	F95P2924-00
	30"	F95R2930-00	F95T2930-00	F95P2930-00
	36"	F95R2936-00	F95T2936-00	F95P2936-00
	42"	F95R2942-00	F95T2942-00	F95P2942-00
	48"	F95R2948-00	F95T2948-00	F95P2948-00
	54"	F95R2954-00	F95T2954-00	F95P2954-00
	60"	F95R2960-00	F95T2960-00	F95P2960-00
	66"	F95R2966-00	F95T2966-00	F95P2966-00
	72"	F95R2972-00	F95T2972-00	F95P2972-00

Color Option Code

Kemresin

BK = Black **GR** = Grey **PT**=Putty **SL** = Slate

Kemresin is available in four standard colors. To specify Kemresin color, place a dash and the two-letter code at the end of the part number.

Example: F95R2324-00-**BK** for Black

If no color is specified, Kemresin will be furnished in Black.

Phenolic Resin - High Pressure Laminate

Phenolic Resin and High Pressure Laminate is furnished in Black standard.

Corner Worksurface Tops

Specifications:

Worksurface Tops are available in modular sizes to match the length and depth of the Worksurface Frames. They are also available in depths 1" less than the Worksurface Frames to create a "Cord Gap" behind the top. This gap allows cords, cables and flexible tubing to be routed below the worksurface, and out of the way of ongoing work.

Worksurface Tops are 1" thick. Front edges are treated as shown on page 69 All other edges are finished square.

When Worksurface Tops spanning more than one frame are desired or when cutouts are required, custom tops are available. See page 70 and 71 for more information.

Modular Corner Worksurface Tops

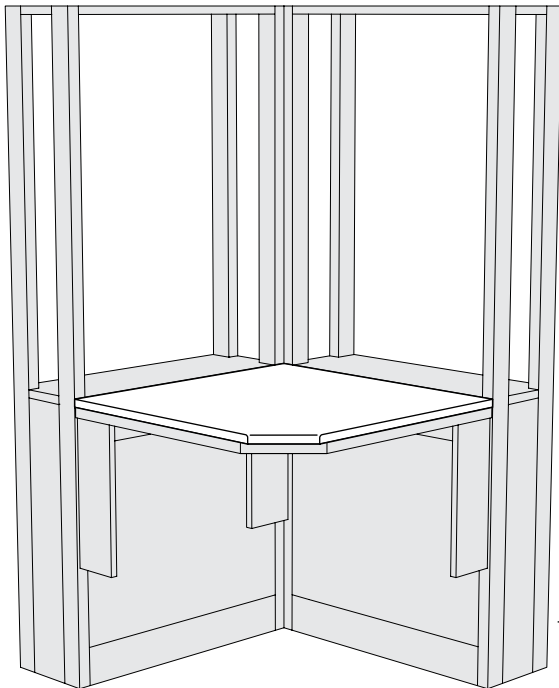

Depth	Length	Kemresin®	Phenolic Resin	High Pressure Laminate
23"	36"	F96R2336-00	F96T2336-00	F96P2336-00
23"	42"	F96R2342-00	F96T2342-00	F96P2342-00
23"	48"	F96R2348-00	F96T2348-00	F96P2348-00
24"	36"	F96R2436-00	F96T2436-00	F96P2436-00
24"	42"	F96R2442-00	F96T2442-00	F96P2442-00
24"	48"	F96R2448-00	F96T2448-00	F96P2448-00
29"	36"	F96R2936-00	F96T2936-00	F96P2936-00
29"	42"	F96R2942-00	F96T2942-00	F96P2942-00
29"	48"	F96R2948-00	F96T2948-00	F96P2948-00
30"	36"	F96R3036-00	F96T3036-00	F96P3036-00
30"	42"	F96R3042-00	F96T3042-00	F96P3042-00
30"	48"	F96R3048-00	F96T3048-00	F96P3048-00

Color Option Code

Kemresin

BK = Black **GR** = Grey **PT**=Putty **SL** = Slate

Kemresin is available in four standard colors. To specify Kemresin color, place a dash and the two-letter code at the end of the part number.

Example: F96R2336-00-**BK** for Black

If no color is specified, Kemresin will be furnished in Black.

Phenolic Resin - High Pressure Laminate

Phenolic Resin and High Pressure Laminate is furnished in Black standard.

Work Top and Ledge Materials

Specifications:

Worksurface Top and Ledge material selections are among the most critical of the laboratory furniture decisions. The intended applications of your work tops dictate material choice. Surfaces could be exposed to reagents and caustic substances. Heavy equipment may need to be supported or only light duty tasks may be performed.

Kewaunee offers three basic work top materials for use on the Alpha System. They are Kewaunee's exclusive Kemresin®, Phenolic Resin and High Pressure Plastic Laminates. All are available in standard sizes to match the Alpha System modules and are complimented with appropriate sinks, drains and accessories.

Work Top and Ledge Material Comparison

MATERIAL	APPEARANCE	COMPOSITION	CHEMICAL RESISTANCE	APPLICATIONS
KEMRESIN®	Black, Grey, Putty, or Slate, ultra-smooth, non-porous	1" thick molded epoxy resin	Excellent resistance to practically all acids, alkalies and solvents	Use wherever optimum physical and chemical resisting properties are required
PHENOLIC RESIN	Hard, smooth surface, various colors	Cellulose fiber reinforced phenolic resin core with a highly crosslinked polyurethane copolymer surface	Excellent resistance to practically all acids, alkalies and solvents	Chemical and biological labs
HIGH PRESSURE LAMINATES	Hard, smooth surface, various colors	Plastic laminate surface attached with water resistant adhesive to solid particle board	Fair chemical resistance to wide range of acids, alkalies and solvents (Strong reagent solutions do attack, and material is almost impossible to repair satisfactorily)	Recommended for light duty purposes in science and technical laboratories or educational institutions, and for pharmacies and nurses stations in hospitals

Work Top Styles — Front Edge



Kewaunee KEMRESIN®
1/8" Chamfer

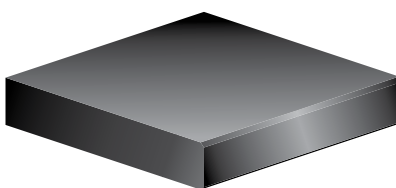

Phenolic Resin
1/8" Chamfer

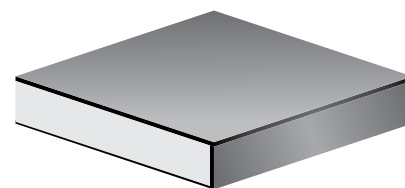

HIGH PRESSURE LAMINATES
Square – Self-Edged

Color Selection:

Kewaunee KEMRESIN®

Black
Grey
Putty
Slate

PHENOLIC RESIN

Phenolic Resin is furnished Black as standard. Other colors and patterns are available on special order. Contact your Kewaunee representative for current offerings.

HIGH PRESSURE LAMINATES

High-Pressure Laminate is furnished Black as standard. Other colors and patterns are available on special order. Contact your Kewaunee representative for current offerings.

Custom Worksurface Tops and Ledges

Specifications:

Recognizing that requirements for laboratory service fixtures and fittings is highly individualized, and that no one solution works in all cases, Alpha System Ledges and Worksurface Tops may be modified to accommodate fixture, fitting, sink, drain, and accessory cutouts as required.

Kewaunee's nationwide network of sales representatives and designers are available to help.

Worksurface Tops and Ledges with Holes and Cutouts

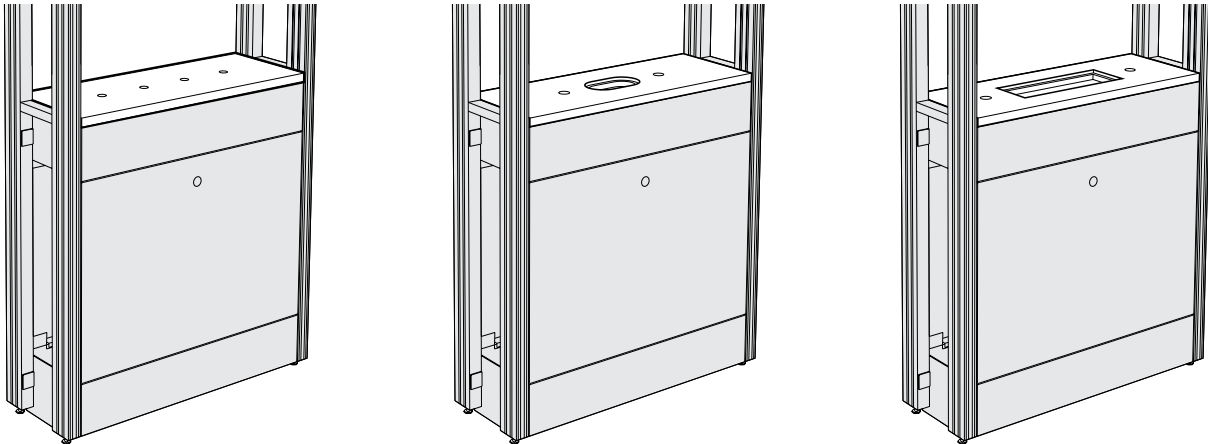

Module ledges may be ordered with cupsink cutouts and/or holes for mounting fittings and fixtures.

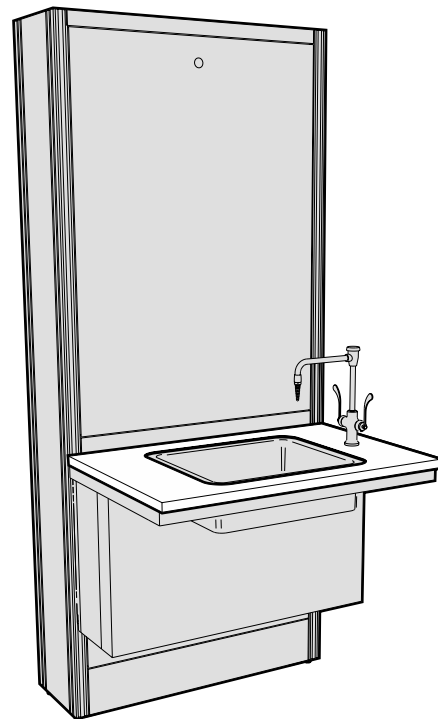
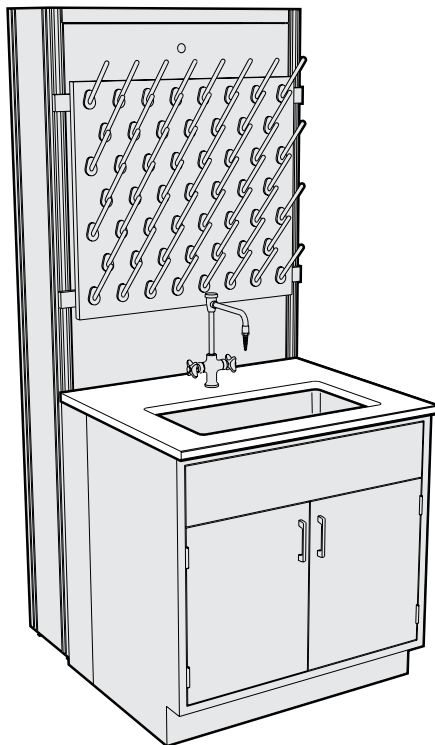

Worksurface tops may be ordered with sink cutouts, service fitting holes, specialty cutouts or other modifications.

Custom Work Tops

Specifications:
 Continuous worksurface tops are available in two basic styles for applications that require an uninterrupted surface. All three top materials, Kemresin, Phenolic Resin, and High Pressure Laminate, may be fabricated into both flat tops, or flat tops with 1" thick applied curbs at the rear.
 Fitting and fixture holes and cutouts can be incorporated in these styles to allow unlimited design options.
 See charts below for material size and color options.

1" Thick Flat Worksurface Top

Standard Depths 24" 30"

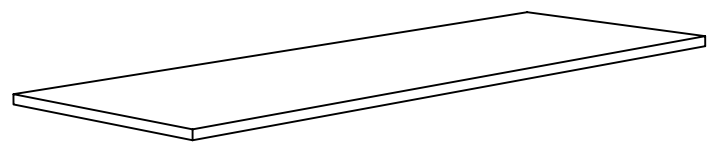

Available Materials	Maximum Length without Joint
Kewaunee Kemresin®	96"
Phenolic Resin	120"
High Pressure Laminate	120"

1" Thick Worksurface Top with 1" x 4" Applied Curb

Standard Depths 24" 30"

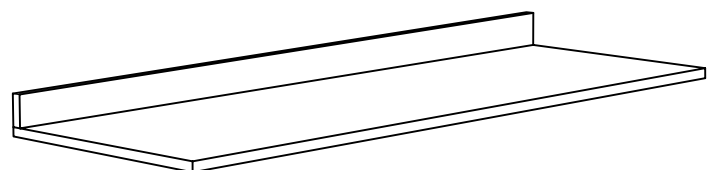

Available Materials	Maximum Length without Joint
Kewaunee Kemresin®	96"
Phenolic Resin	120"
High Pressure Laminate	120"

Color Selection:

Kewaunee KEMRESIN®
 Black
 Grey
 Putty
 Slate

PHENOLIC RESIN
 Phenolic Resin is furnished Black as standard. Other colors and patterns are available on special order. Contact your Kewaunee representative for current offerings.

HIGH PRESSURE LAMINATES
 High-Pressure Laminate is furnished Black as standard. Other colors and patterns are available on special order. Contact your Kewaunee representative for current offerings.

Suspended Base Cabinets

Features:

Steel Base Cabinets

- Electrostatically applied, chemical resistant, powder coat finish available in colors to compliment the laboratory environment
- Heavy gauge formed and welded steel cabinet body construction provides strength and durability
- One piece drawer body-bottom, back, sides and inner drawer head, radiused all four sides
- Full-extension, side mounted, soft-close slides.
- One-piece case bottom and horizontal front rail
- Flush face corner construction
- Five-knuckle institutional type stainless steel hinge, 2³/₄" high

Wood Base Cabinets

- Multiple coat, chemical resistant finish system formulated to highlight the natural grain patterns
- Dovetailed drawer construction with nine-ply hardwood plywood drawer sides
- 3/4" seven-ply hardwood plywood end panels, bottom and shelf, with solid hardwood facing
- Full-extension, ball bearing, drawer slides
- One-piece 1/4" hardboard back, dadoed into end panels and bottom and securely fastened
- Five-knuckle institutional type stainless steel offset door hinges rated for 150 pound loads



Suspended Base Cabinets – 19" High

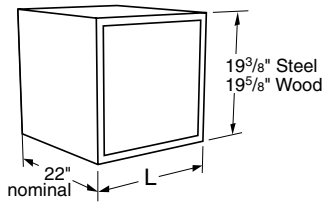

Specifications:

Suspended Base Cabinets are designed to hang beneath Cantilevered Worksurface or Table Frames. They are available in either steel or wood construction and are furnished with all hardware required for attachment to the frame.

Cabinets on this page are a nominal 19" high, and are available in lengths shown.

See page 98 and 99 for designating cabinet style, door and drawer head material, and hardware selection.

Open Base Cabinets



Steel Cabinet	Length	Wood Cabinet
B00C192215-00_0	15"	B00W202215-00_0
B00C192218-00_0	18"	B00W202218-00_0
B00C192221-00_0	21"	B00W202221-00_0
B00C192224-00_0	24"	B00W202224-00_0

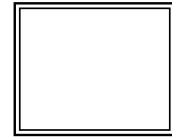

Steel Cabinet	Length	Wood Cabinet
B00C192230-00_0	30"	B00W202230-00_0
B00C192236-00_0	36"	B00W202236-00_0
B00C192242-00_0	42"	B00W202242-00_0
B00C192248-00_0	48"	B00W202248-00_0

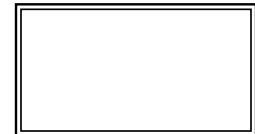

Cupboard Base Cabinets

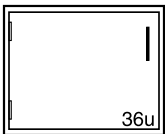

Steel Cabinet	Length	Wood Cabinet
C03C192215L	15"	C03W202215L
C03C192218L	18"	C03W202218L
C03C192221L	21"	C03W202221L
C03C192224L	24"	C03W202224L

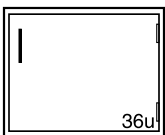
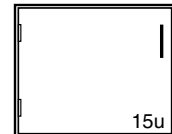

Steel Cabinet	Length	Wood Cabinet
C03C192215-	15"	C03W202215-
C03C192218-	18"	C03W202218-
C03C192221-	21"	C03W202221-
C03C192224-	24"	C03W202224-

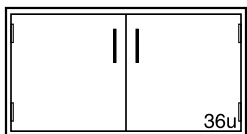
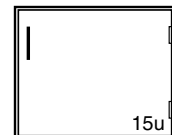

Steel Cabinet	Length	Wood Cabinet
C03C192230-	30"	C03W202230-
C03C192236-	36"	C03W202236-
C03C192242-	42"	C03W202242-
C03C192248-	48"	C03W202248-

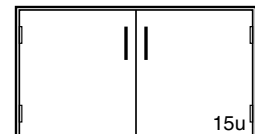

Suspended Base Cabinets – 19" High

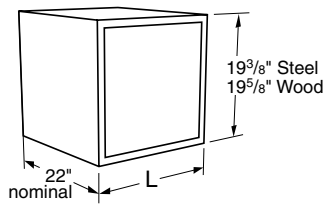

Specifications:
 Suspended Base Cabinets are designed to hang beneath Cantilevered Worksurface or Table Frames. They are available in either steel or wood construction and are furnished with all hardware required for attachment to the frame.

Cabinets on this page are a nominal 19" high, and are available in lengths shown.

See page 98 and 99 for designating cabinet style, door and drawer head material, and hardware selection.

Drawer Base Cabinets

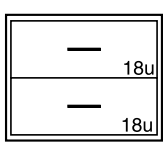

Steel Cabinet	Length	Wood Cabinet
D00C192215- -----	15"	D00W202215- 0 -----
D00C192218- -----	18"	D00W202218- 0 -----
D00C192221- -----	21"	D00W202221- 0 -----
D00C192224- -----	24"	D00W202224- 0 -----

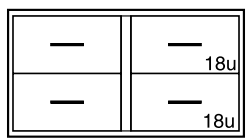
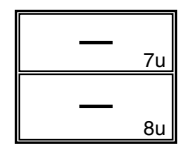

Steel Cabinet	Length	Wood Cabinet
D02C192230- -----	30"	D02W202230- 0 -----
D02C192236- -----	36"	D02W202236- 0 -----
D02C192242- -----	42"	D02W202242- 0 -----
D02C192248- -----	48"	D02W202248- 0 -----

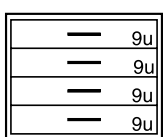
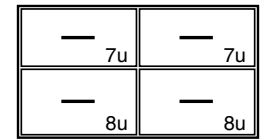

Steel Cabinet	Length	Wood Cabinet
D30C192215- -----	15"	D30W202215- 0 -----
D30C192218- -----	18"	D30W202218- 0 -----
D30C192221- -----	21"	D30W202221- 0 -----
D30C192224- -----	24"	D30W202224- 0 -----

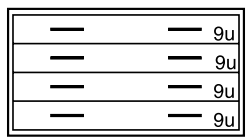
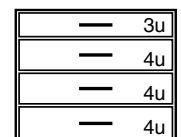

Steel Cabinet	Length	Wood Cabinet
D30C192230- -----	30"	D30W202230- 0 -----
D30C192236- -----	36"	D30W202236- 0 -----
D30C192242- -----	42"	D30W202242- 0 -----
D30C192248- -----	48"	D30W202248- 0 -----

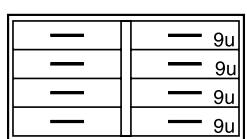
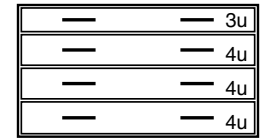

Steel Cabinet	Length	Wood Cabinet
D32C192230- -----	30"	D32W202230- 0 -----
D32C192236- -----	36"	D32W202236- 0 -----
D32C192242- -----	42"	D32W202242- 0 -----
D32C192248- -----	48"	D32W202248- 0 -----

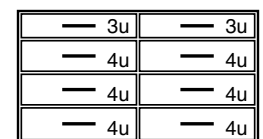

Suspended Base Cabinets – 19" High

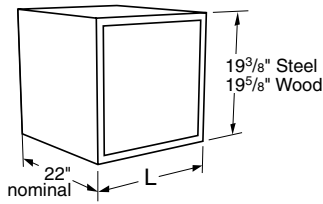

Specifications:

Suspended Base Cabinets are designed to hang beneath Cantilevered Worksurface or Table Frames. They are available in either steel or wood construction and are furnished with all hardware required for attachment to the frame.

Cabinets on this page are a nominal 19" high, and are available in lengths shown.

See page 98 and 99 for designating cabinet style, door and drawer head material, and hardware selection.

Drawer Base Cabinets

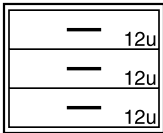

Steel Cabinet	Length	Wood Cabinet
D50C192215- -----	15"	D50W202215- 0
D50C192218- -----	18"	D50W202218- 0
D50C192221- -----	21"	D50W202221- 0
D50C192224- -----	24"	D50W202224- 0

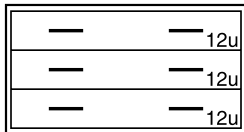
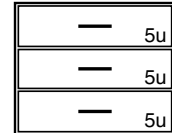

Steel Cabinet	Length	Wood Cabinet
D50C192230- -----	30"	D50W202230- 0
D50C192236- -----	36"	D50W202236- 0
D50C192242- -----	42"	D50W202242- 0
D50C192248- -----	48"	D50W202248- 0

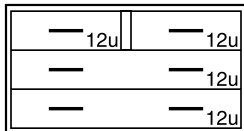
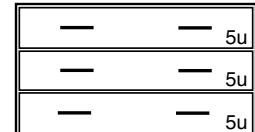

Steel Cabinet	Length	Wood Cabinet
D51C192230- -----	30"	D51W202230- 0
D51C192236- -----	36"	D51W202236- 0
D51C192242- -----	42"	D51W202242- 0
D51C192248- -----	48"	D51W202248- 0

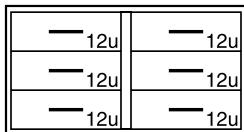
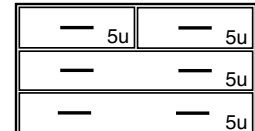

Steel Cabinet	Length	Wood Cabinet
D52C192230- -----	30"	D52W202230- 0
D52C192236- -----	36"	D52W202236- 0
D52C192242- -----	42"	D52W202242- 0
D52C192248- -----	48"	D52W202248- 0

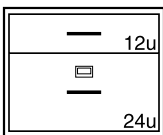
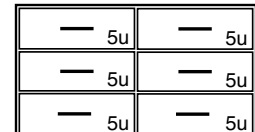

Steel Cabinet	Length	Wood Cabinet
D81C192215- -----	15"	D81W202215- 0
D81C192218- -----	18"	D81W202218- 0
D81C192221- -----	21"	D81W202221- 0
D81C192224- -----	24"	D81W202224- 0

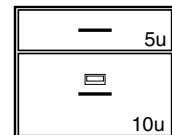

1 File Drawer with hangers

1 File Drawer with hangers

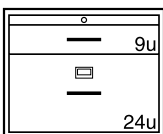

Steel Cabinet	Length	Wood Cabinet
D85C192215- -----	15"	D85W202215- 0
D85C192218- -----	18"	D85W202218- 0
D85C192221- -----	21"	D85W202221- 0
D85C192224- -----	24"	D85W202224- 0

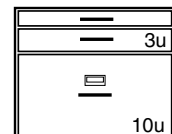

Pullboard

1 File Drawer with hangers

Pullboard

1 File Drawer with hangers

Suspended Base Cabinets – 19" High

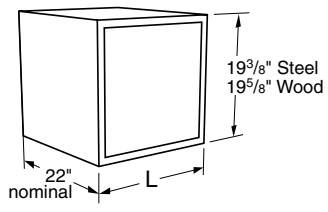

Specifications:
 Suspended Base Cabinets are designed to hang beneath Cantilevered Worksurface or Table Frames. They are available in either steel or wood construction and are furnished with all hardware required for attachment to the frame.

Cabinets on this page are a nominal 19" high, and are available in lengths shown.

See page 98 and 99 for designating cabinet style, door and drawer head material, and hardware selection.

Drawer Base Cabinets

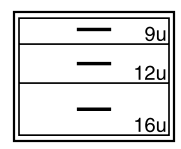

Steel Cabinet	Length	Wood Cabinet
D86C192215- -----	15"	D86W202215- 0 -----
D86C192218- -----	18"	D86W202218- 0 -----
D86C192221- -----	21"	D86W202221- 0 -----
D86C192224- -----	24"	D86W202224- 0 -----

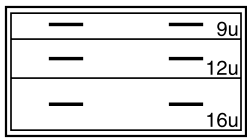
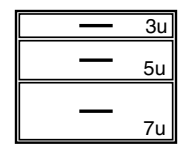

Steel Cabinet	Length	Wood Cabinet
D86C192230- -----	30"	D86W202230- 0 -----
D86C192236- -----	36"	D86W202236- 0 -----
D86C192242- -----	42"	D86W202242- 0 -----
D86C192248- -----	48"	D86W202248- 0 -----

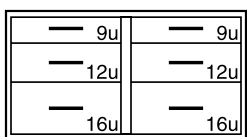
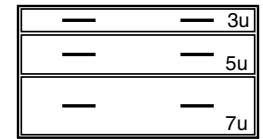

Steel Cabinet	Length	Wood Cabinet
D87C192230- -----	30"	D87W202230- 0 -----
D87C192236- -----	36"	D87W202236- 0 -----
D87C192242- -----	42"	D87W202242- 0 -----
D87C192248- -----	48"	D87W202248- 0 -----

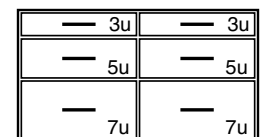

Drawer & Cupboard Base Cabinets

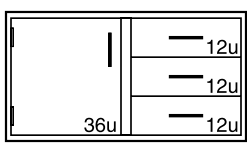

Steel Cabinet	Length	Wood Cabinet
E43C192230L -----	30"	E43W202230L -----
E43C192236L -----	36"	E43W202236L -----
E43C192242L -----	42"	E43W202242L -----
E43C192248L -----	48"	E43W202248L -----

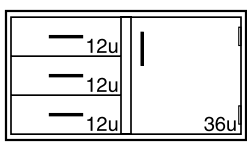
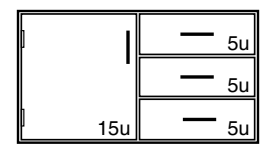

Steel Cabinet	Length	Wood Cabinet
E43C192230- -----	30"	E43W202230- -----
E43C192236- -----	36"	E43W202236- -----
E43C192242- -----	42"	E43W202242- -----
E43C192248- -----	48"	E43W202248- -----

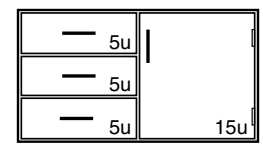

Suspended Base Cabinets – 25" High

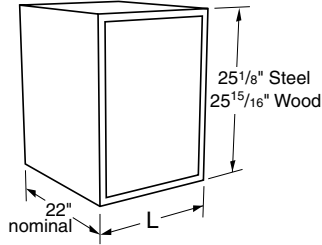

Specifications:

Suspended Base Cabinets are designed to hang beneath Cantilevered Worksurface or Table Frames. They are available in either steel or wood construction and are furnished with all hardware required for attachment to the frame.

Cabinets on this page are a nominal 25" high, and are available in lengths shown.

See page 98 and 99 for designating cabinet style, door and drawer head material, and hardware selection.

Open Base Cabinets

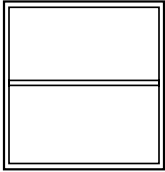

Steel Cabinet	Length	Wood Cabinet
B00C252215-00_0	15"	B00W262215-00_0
B00C252218-00_0	18"	B00W262218-00_0
B00C252221-00_0	21"	B00W262221-00_0
B00C252224-00_0	24"	B00W262224-00_0

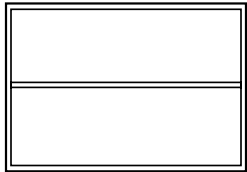
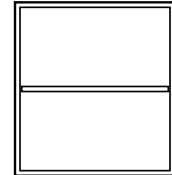

Steel Cabinet	Length	Wood Cabinet
B00C252230-00_0	30"	B00W262230-00_0
B00C252236-00_0	36"	B00W262236-00_0
B00C252242-00_0	42"	B00W262242-00_0
B00C252248-00_0	48"	B00W262248-00_0



Cupboard Base Cabinets

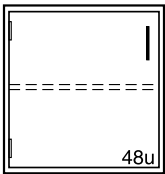

Steel Cabinet	Length	Wood Cabinet
C03C252215L	15"	C03W262215L_0
C03C252218L	18"	C03W262218L_0
C03C252221L	21"	C03W262221L_0
C03C252224L	24"	C03W262224L_0

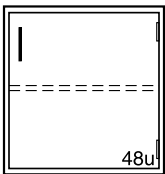
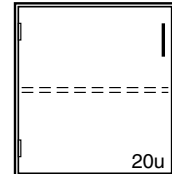

Steel Cabinet	Length	Wood Cabinet
C03C252215-	15"	C03W262215-_0
C03C252218-	18"	C03W262218-_0
C03C252221-	21"	C03W262221-_0
C03C252224-	24"	C03W262224-_0

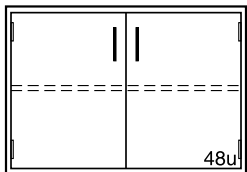
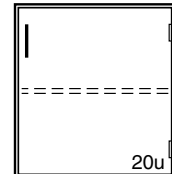

Steel Cabinet	Length	Wood Cabinet
C03C252230-	30"	C03W262230-_0
C03C252236-	36"	C03W262236-_0
C03C252242-	42"	C03W262242-_0
C03C252248-	48"	C03W262248-_0

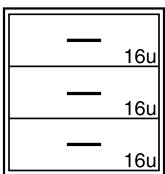
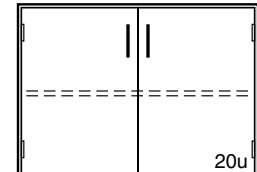

Steel Cabinet	Length	Wood Cabinet
D00C252215-	15"	D00W262215-_0
D00C252218-	18"	D00W262218-_0
D00C252221-	21"	D00W262221-_0
D00C252224-	24"	D00W262224-_0

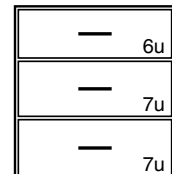

Suspended Base Cabinets – 25" High

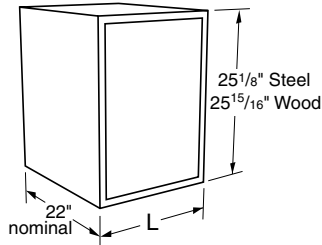

Specifications:

Suspended Base Cabinets are designed to hang beneath Cantilevered Worksurface or Table Frames. They are available in either steel or wood construction and are furnished with all hardware required for attachment to the frame.

Cabinets on this page are a nominal 25" high, and are available in lengths shown.

See page 98 and 99 for designating cabinet style, door and drawer head material, and hardware selection.

Cupboard Base Cabinets

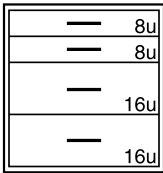

Steel Cabinet	Length	Wood Cabinet
D08C252215- ----	15"	D08W262215- 0
D08C252218- ----	18"	D08W262218- 0
D08C252221- ----	21"	D08W262221- 0
D08C252224- ----	24"	D08W262224- 0

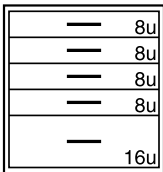
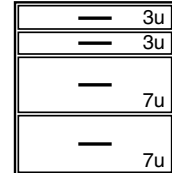

Steel Cabinet	Length	Wood Cabinet
D10C252215- ----	15"	D10W262215- 0
D10C252218- ----	18"	D10W262218- 0
D10C252221- ----	21"	D10W262221- 0
D10C252224- ----	24"	D10W262224- 0

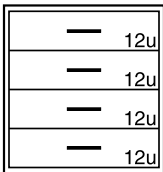
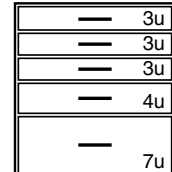

Steel Cabinet	Length	Wood Cabinet
D30C252215- ----	15"	D30W262215- 0
D30C252218- ----	18"	D30W262218- 0
D30C252221- ----	21"	D30W262221- 0
D30C252224- ----	24"	D30W262224- 0

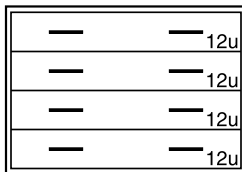
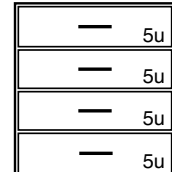

Steel Cabinet	Length	Wood Cabinet
D30C252230- ----	30"	D30W262230- 0
D30C252236- ----	36"	D30W262236- 0
D30C252242- ----	42"	D30W262242- 0
D30C252248- ----	48"	D30W262248- 0

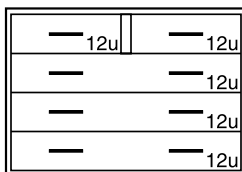
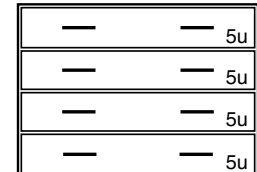

Steel Cabinet	Length	Wood Cabinet
D31C252230- ----	30"	D31W262230- 0
D31C252236- ----	36"	D31W262236- 0
D31C252242- ----	42"	D31W262242- 0
D31C252248- ----	48"	D31W262248- 0

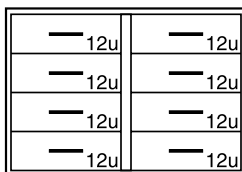
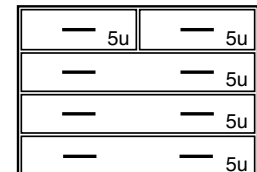

Steel Cabinet	Length	Wood Cabinet
D32C252230- ----	30"	D32W262230- 0
D32C252236- ----	36"	D32W262236- 0
D32C252242- ----	42"	D32W262242- 0
D32C252248- ----	48"	D32W262248- 0

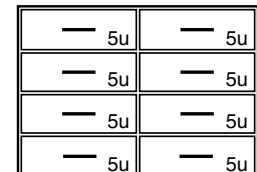

Suspended Base Cabinets – 25" High

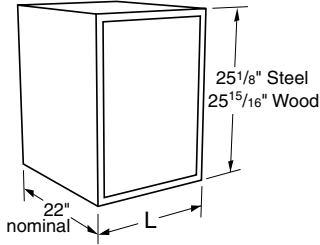

Specifications:

Suspended Base Cabinets are designed to hang beneath Cantilevered Worksurface or Table Frames. They are available in either steel or wood construction and are furnished with all hardware required for attachment to the frame.

Cabinets on this page are a nominal 25" high, and are available in lengths shown.

See page 98 and 99 for designating cabinet style, door and drawer head material, and hardware selection.

Drawer Base Cabinets

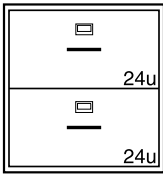

2 File Drawers with hangers

Steel Cabinet	Length	Wood Cabinet
D81C252215L	15"	D81W262215- 0
D81C252218L	18"	D81W262218- 0
D81C252221L	21"	D81W262221- 0
D81C252224L	24"	D81W262224- 0

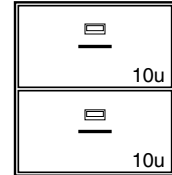

2 File Drawers with hangers

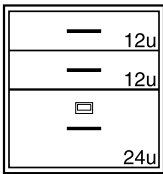

1 File Drawer with hangers

Steel Cabinet	Length	Wood Cabinet
D85C252215-	15"	D85W262215- 0
D85C252218-	18"	D85W262218- 0
D85C252221-	21"	D85W262221- 0
D85C252224-	24"	D85W262224- 0

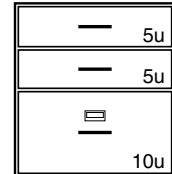

1 File Drawer with hangers

Drawer & Cupboard Base Cabinets

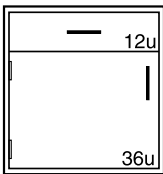

Steel Cabinet	Length	Wood Cabinet
E40C252215L	15"	E40W262215L
E40C252218L	18"	E40W262218L
E40C252221L	21"	E40W262221L
E40C252224L	24"	E40W262224L

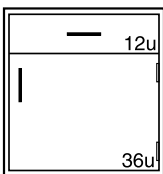
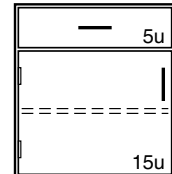

Steel Cabinet	Length	Wood Cabinet
E40C252215-	15"	E40W262215-
E40C252218-	18"	E40W262218-
E40C252221-	21"	E40W262221-
E40C252224-	24"	E40W262224-

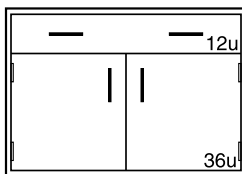
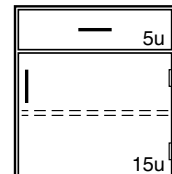

Steel Cabinet	Length	Wood Cabinet
E40C252230-	30"	E40W262230-
E40C252236-	36"	E40W262236-
E40C252242-	42"	E40W262242-
E40C252248-	48"	E40W262248-

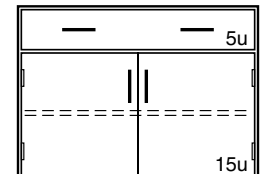

Suspended Base Cabinets – 25" High

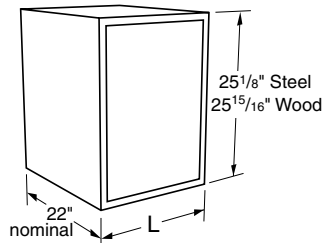

Specifications:
 Suspended Base Cabinets are designed to hang beneath Cantilevered Worksurface or Table Frames. They are available in either steel or wood construction and are furnished with all hardware required for attachment to the frame.

Cabinets on this page are a nominal 25" high, and are available in lengths shown.

See page 98 and 99 for designating cabinet style, door and drawer head material, and hardware selection.

Drawer & Cupboard Base Cabinets

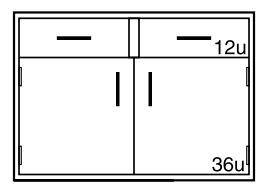

Steel Cabinet	Length	Wood Cabinet
E41C252230- -----	30"	E41W262230- -----
E41C252236- -----	36"	E41W262236- -----
E41C252242- -----	42"	E41W262242- -----
E41C252248- -----	48"	E41W262248- -----

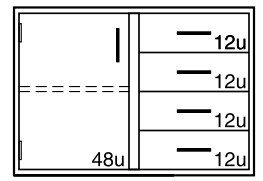
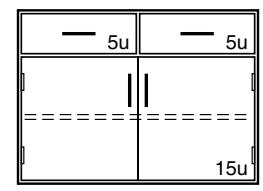

Steel Cabinet	Length	Wood Cabinet
E44C252230L -----	30"	E44W262230L -----
E44C252236L -----	36"	E44W262236L -----
E44C252242L -----	42"	E44W262242L -----
E44C252248L -----	48"	E44W262248L -----

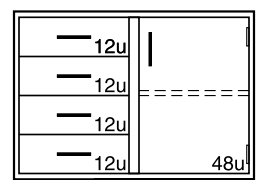
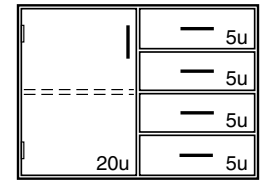

Steel Cabinet	Length	Wood Cabinet
E44C252230- -----	30"	E44W262230- -----
E44C252236- -----	36"	E44W262236- -----
E44C252242- -----	42"	E44W262242- -----
E44C252248- -----	48"	E44W262248- -----

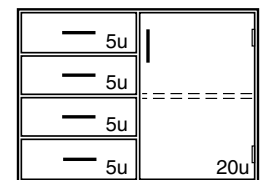

Sink Base Cabinets

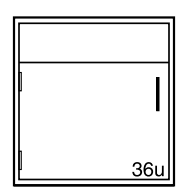

Steel Cabinet	Length	Wood Cabinet
G00C252215L -----	15"	G00W262215L -----
G00C252218L -----	18"	G00W262218L -----
G00C252221L -----	21"	G00W262221L -----
G00C252224L -----	24"	G00W262224L -----

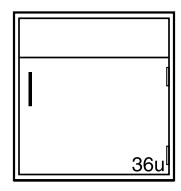
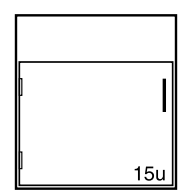

Steel Cabinet	Length	Wood Cabinet
G00C252215- -----	15"	G00W262215- -----
G00C252218- -----	18"	G00W262218- -----
G00C252221- -----	21"	G00W262221- -----
G00C252224- -----	24"	G00W262224- -----

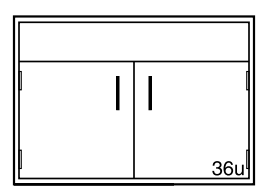
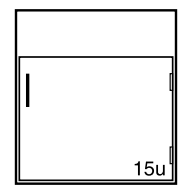

Steel Cabinet	Length	Wood Cabinet
G00C252230- -----	30"	G00W262230- -----
G00C252236- -----	36"	G00W262236- -----
G00C252242- -----	42"	G00W262242- -----
G00C252248- -----	48"	G00W262248- -----

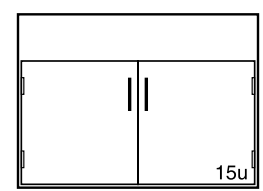

Illustrations and specifications are based on most current design and production information available. Kewaunee reserves the right to make changes at any time without notice.

Drawers, Writing Boards & Keyboard Tray

Specifications:

Suspended Drawers and Writing Boards are designed to hang beneath Cantilevered Worksurface. They are available in either steel or wood construction and are furnished with all hardware required for attachment to the frame.

See page 98 and 99 for designating cabinet style, drawer head material, and hardware selection.

The black, non-skid, vinyl coated, MDF Keyboard Tray is furnished with sliding support arm offering 21" of travel, 5³/₄" of height adjustment, +/- 15° tilt, and 360° swivel. Optional Mouse Pad may be mounted to either side of Keyboard Tray and pivots under tray when not in use. Both are supplied with all hardware required for mounting to Worksurfaces, Tables, or Shelves.

Suspended Drawers - 4" High

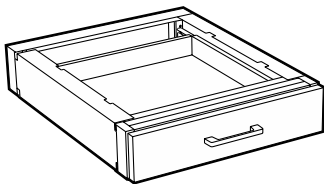

Length	Steel	Wood
15"	F70C042215-1 ___	F70W042215- 0 ___
18"	F70C042218-1 ___	F70W042218- 0 ___
21"	F70C042221-1 ___	F70W042221- 0 ___
24"	F70C042224-1 ___	F70W042224- 0 ___
30"	F70C042230-1 ___	F70W042230- 0 ___

Suspended Writing Boards

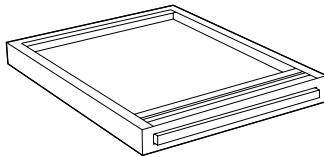

Length	Steel	Wood
15"	F71C022215-00_0	F71W022215-00_0
18"	F71C022218-00_0	F71W022218-00_0

Keyboard Trays

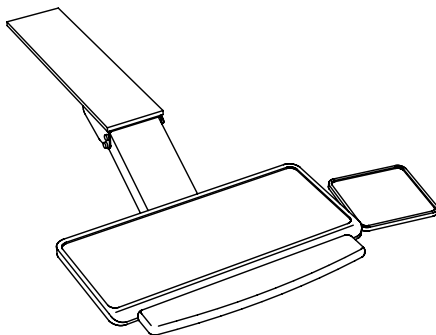

Sliding Keyboard Tray polycarbonate coated steel	11 ¹ / ₂ " x 20 ¹ / ₂ " F72M1220-00
Optional Swing-out Mouse Platform polycarbonate coated steel	8" x 8" F72M0808-0T

product may vary slightly from illustration

Mobile Base Cabinets

Features:

Steel Base Cabinets

- Furnished with finished ends and back.
- Cabinet tops available in either, Kemresin, Phenolic Resin, High Pressure Laminate or Steel.
- Furnished with two concealed, fixed casters at rear, and two swivel, locking casters at front.
- Furnished with interlocking drawer system and counterbalanced weights in drawer cabinets.
- Available in all steel cabinet styles, in both inset and full overlay.

Wood Base Cabinets

- Furnished with finished veneer top, end panels, and back. End panels banded and finished, front, back, top, and bottom.
- Optional 1" thick cabinet tops available. (recommended for wood cabinets with pullboards)
- Furnished with two concealed, fixed casters at rear, and two swivel, locking casters at front.
- Furnished with interlocking drawer system and counterbalanced weights in drawer cabinets.
- Available in three wood cabinet styles in Oak, Maple, or Beech veneer.

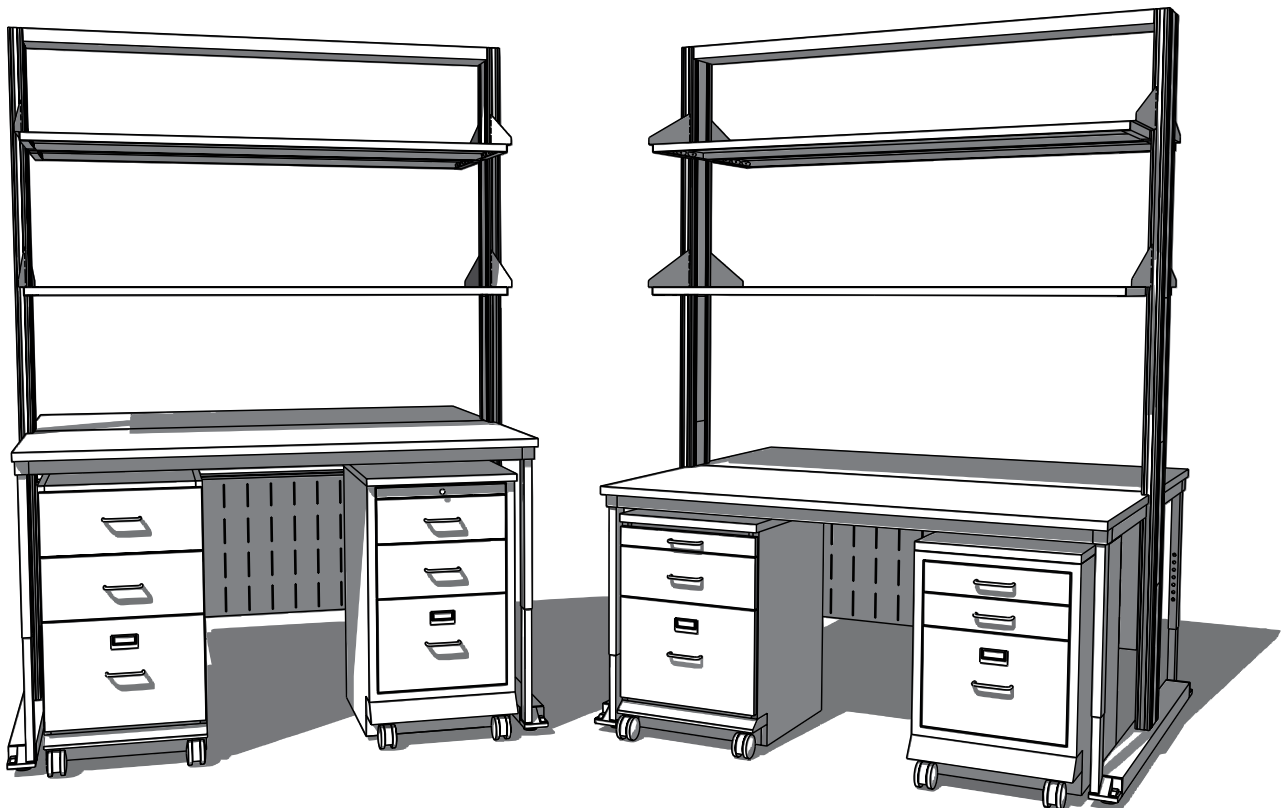

Wood Sitting Height Mobile Cabinets

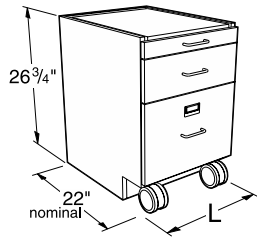

Specifications:

These Mobile Cabinets are 26³/₄" high and a nominal 22" deep. Lengths as shown. They are designed to fit under 30" high worksurface frames.

Drawer cabinets are furnished with counter weights, multiple-drawer cabinets include an interlock system. All mobile cabinets have finished backs.

Note: Last four digits of part number designates door and drawer head style, hinge, hardwood species, and pull selection. See page 99 for full explanation. Actual product may vary slightly from catalog illustration due to style and hardware selection.

Cupboard Cabinets

Cupboard Cabinets with Pullboards

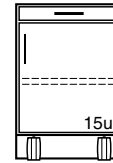
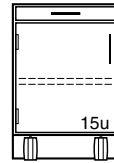
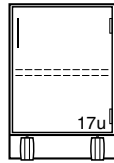
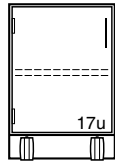

M10W272215L _____ 15"
M10W272218L _____ 18"
M10W272221L _____ 21"
M10W272224L _____ 24"

M10W272215- _____ 15"
M10W272218- _____ 18"
M10W272221- _____ 21"
M10W272224- _____ 24"

M15W272215L _____ 15"
M15W272218L _____ 18"
M15W272221L _____ 21"
M15W272224L _____ 24"

M15W272215- _____ 15"
M15W272218- _____ 18"
M15W272221- _____ 21"
M15W272224- _____ 24"

Drawer/Cupboard Cabinets

Drawer/Cupboard Cabinets with Pullboards

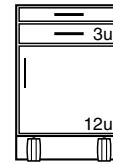
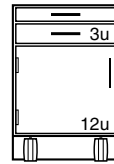
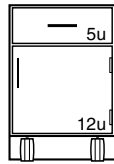
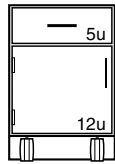

M20W272215L _____ 15"
M20W272218L _____ 18"
M20W272221L _____ 21"
M20W272224L _____ 24"

M20W272215- _____ 15"
M20W272218- _____ 18"
M20W272221- _____ 21"
M20W272224- _____ 24"

M25W272215L _____ 15"
M25W272218L _____ 18"
M25W272221L _____ 21"
M25W272224L _____ 24"

M25W272215- _____ 15"
M25W272218- _____ 18"
M25W272221- _____ 21"
M25W272224- _____ 24"

Drawer Cabinets

Drawer Cabinets with Pullboards

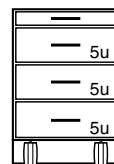
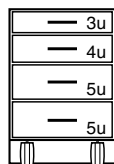
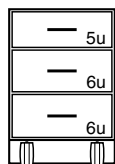

M30W272215- _____ 15"
M30W272218- _____ 18"
M30W272221- _____ 21"
M30W272224- _____ 24"

M40W272215- _____ 15"
M40W272218- _____ 18"
M40W272221- _____ 21"
M40W272224- _____ 24"

M35W272215- _____ 15"
M35W272218- _____ 18"
M35W272221- _____ 21"
M35W272224- _____ 24"

Note: Wood Mobile Cabinets are constructed with finished top panels. Tops may be added but are not required to close the top of the cabinet.

Tops are recommended on wood mobile cabinets with pullboards.

Tops must be ordered separately. (see page 133)

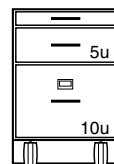
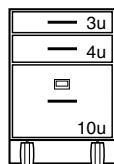
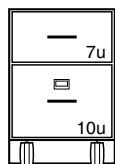

M60W272215- _____ 15"
M60W272218- _____ 18"
M60W272221- _____ 21"
M60W272224- _____ 24"

M62W272215- _____ 15"
M62W272218- _____ 18"
M62W272221- _____ 21"
M62W272224- _____ 24"

M65W272215- _____ 15"
M65W272218- _____ 18"
M65W272221- _____ 21"
M65W272224- _____ 24"

Wood Standing Height Mobile Cabinets

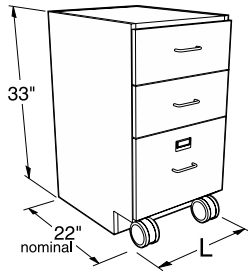

Specifications:

These Mobile Cabinets are 33" high and a nominal 22" deep. Lengths as shown. They are designed to fit under 36" high worksurface frames.

Drawer cabinets are furnished with counter weights, multiple-drawer cabinets include an interlock system. All mobile cabinets have finished backs.

Note: Last four digits of part number designates door and drawer head style, hinge, hardwood species, and pull selection. See page 99 for full explanation. Actual product may vary slightly from catalog illustration due to style and hardware selection.

Cupboard Cabinets

Cupboard Cabinets with Pullboards

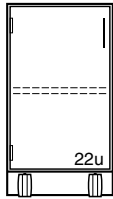

- M10W332215L _____ 15"L
- M10W332218L _____ 18"L
- M10W332221L _____ 21"L
- M10W332224L _____ 24"L

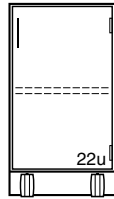

- M10W332215- _____ 15"L
- M10W332218- _____ 18"L
- M10W332221- _____ 21"L
- M10W332224- _____ 24"L

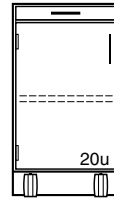

- M15W332215L _____ 15"L
- M15W332218L _____ 18"L
- M15W332221L _____ 21"L
- M15W332224L _____ 24"L

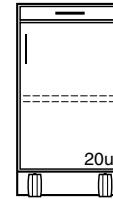

- M15W332215- _____ 15"L
- M15W332218- _____ 18"L
- M15W332221- _____ 21"L
- M15W332224- _____ 24"L

Drawer/Cupboard Cabinets

Drawer/Cupboard Cabinets with Pullboards

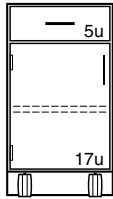

- M20W332215L _____ 15"L
- M20W332218L _____ 18"L
- M20W332221L _____ 21"L
- M20W332224L _____ 24"L

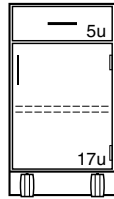

- M20W332215- _____ 15"L
- M20W332218- _____ 18"L
- M20W332221- _____ 21"L
- M20W332224- _____ 24"L



- M25W332215L _____ 15"L
- M25W332218L _____ 18"L
- M25W332221L _____ 21"L
- M25W332224L _____ 24"L

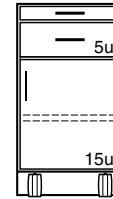

- M25W332215- _____ 15"L
- M25W332218- _____ 18"L
- M25W332221- _____ 21"L
- M25W332224- _____ 24"L

Drawer Cabinets

Drawer Cabinets with Pullboards

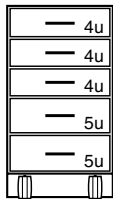

- M50W332215- _____ 15"L
- M50W332218- _____ 18"L
- M50W332221- _____ 21"L
- M50W332224- _____ 24"L

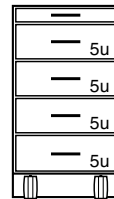

- M45W332215- _____ 15"L
- M45W332218- _____ 18"L
- M45W332221- _____ 21"L
- M45W332224- _____ 24"L

Note: Wood Mobile Cabinets are constructed with finished top panels. Tops may be added but are not required to close the top of the cabinet.

Tops are recommended on wood mobile cabinets with pullboards.

Tops must be ordered separately. (see page 133)

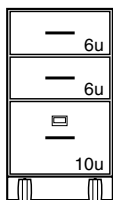

- M62W332215- _____ 15"L
- M62W332218- _____ 18"L
- M62W332221- _____ 21"L
- M62W332224- _____ 24"L

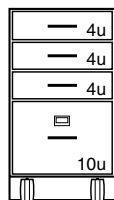

- M63W332215- _____ 15"L
- M63W332218- _____ 18"L
- M63W332221- _____ 21"L
- M63W332224- _____ 24"L

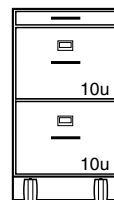

- M75W332215- _____ 15"L
- M75W332218- _____ 18"L
- M75W332221- _____ 21"L
- M75W332224- _____ 24"L

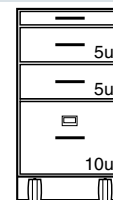

- M67W332215- _____ 15"L
- M67W332218- _____ 18"L
- M67W332221- _____ 21"L
- M67W332224- _____ 24"L

Steel Sitting Height Mobile Cabinets

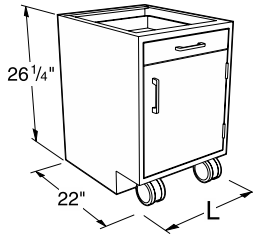

Specifications

Steel Sitting Height Mobile Cabinets are 26 1/4" high and 22" deep. Lengths as shown. Designed to fit under 30" high workstation frames.

Drawer cabinets are furnished with counter weights, multiple-drawer cabinets include an interlock system. All mobile cabinets have finished backs.

Note: Last four digits of part number designates door and drawer head style, hinge, hardwood species and pull selection. See page 98 for full explanation. Actual product may vary slightly from catalog illustration due to style and hardware selection.

Cupboard Cabinets

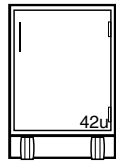
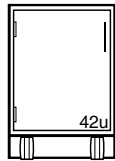

M10C262215L	15"L	M10C262215-	15"L
M10C262218L	18"L	M10C262218-	18"L
M10C262221L	21"L	M10C262221-	21"L
M10C262224L	24"L	M10C262224-	24"L

Note: Steel Mobile Cabinets are constructed with open top frames. Tops are required to close the top of the cabinets.

Tops must be ordered separately.
(see page 132 & 133)

Drawer/Cupboard Cabinets

Drawer/Cupboard Cabinets with Pullboards

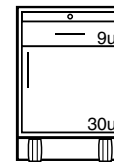
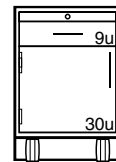
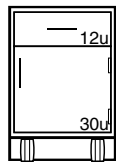
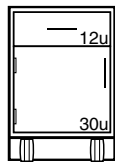

M20C262215L	15"L	M20C262215-	15"L
M20C262218L	18"L	M20C262218-	18"L
M20C262221L	21"L	M20C262221-	21"L
M20C262224L	24"L	M20C262224-	24"L

M25C262215L	15"L	M25C262215-	15"L
M25C262218L	18"L	M25C262218-	18"L
M25C262221L	21"L	M25C262221-	21"L
M25C262224L	24"L	M25C262224-	24"L

Drawer Cabinets

Drawer Cabinets with Pullboards

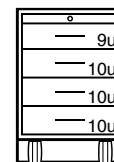
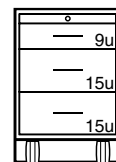
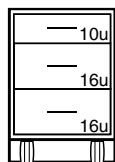

M30C262215-	15"L
M30C262218-	18"L
M30C262221-	21"L
M30C262224-	24"L

M35C262215-	15"L
M35C262218-	18"L
M35C262221-	21"L
M35C262224-	24"L

M45C262215-	15"L
M45C262218-	18"L
M45C262221-	21"L
M45C262224-	24"L

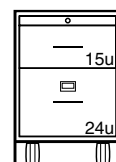
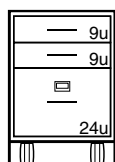

M62C262215-	15"L
M62C262218-	18"L
M62C262221-	21"L
M62C262224-	24"L

M66C262215-	15"L
M66C262218-	18"L
M66C262221-	21"L
M66C262224-	24"L

Steel Standing Height Mobile Cabinets

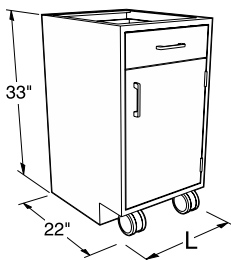

Specifications

Steel Standing Height Mobile Cabinets are 33" high and 22" deep. Lengths as shown. Designed to fit under 36" high workstation frames.

Drawer cabinets are furnished with counter weights, multiple-drawer cabinets include an interlock system. All mobile cabinets have finished backs.

Note: Last four digits of part number designates door and drawer head style, hinge, hardwood species and pull selection. See page 98 for full explanation. Actual product may vary slightly from catalog illustration due to style and hardware selection.

Cupboard Cabinets

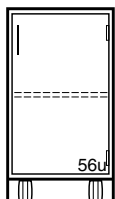
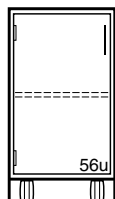

- M10C332215L _____ 15"L
- M10C332218L _____ 18"L
- M10C332221L _____ 21"L
- M10C332224L _____ 24"L

- M10C332215- _____ 15"L
- M10C332218- _____ 18"L
- M10C332221- _____ 21"L
- M10C332224- _____ 24"L

Note: Steel Mobile Cabinets are constructed with open top frames. Tops are required to close the top of the cabinets.

Tops must be ordered separately.
(see page 132 & 133)

Drawer/Cupboard Cabinets

Drawer/Cupboard Cabinets with Pullboards

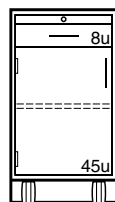
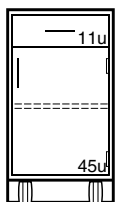
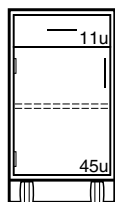

- M20C332215L _____ 15"L
- M20C332218L _____ 18"L
- M20C332221L _____ 21"L
- M20C332224L _____ 24"L

- M20C332215- _____ 15"L
- M20C332218- _____ 18"L
- M20C332221- _____ 21"L
- M20C332224- _____ 24"L

- M25C332215L _____ 15"L
- M25C332218L _____ 18"L
- M25C332221L _____ 21"L
- M25C332224L _____ 24"L

- M25C332215- _____ 15"L
- M25C332218- _____ 18"L
- M25C332221- _____ 21"L
- M25C332224- _____ 24"L

Drawer Cabinets

Drawer Cabinets with Pullboards

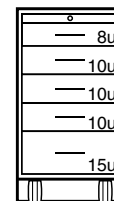
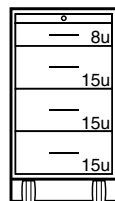
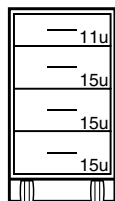

- M40C332215- _____ 15"L
- M40C332218- _____ 18"L
- M40C332221- _____ 21"L
- M40C332224- _____ 24"L

- M46C332215- _____ 15"L
- M46C332218- _____ 18"L
- M46C332221- _____ 21"L
- M46C332224- _____ 24"L

- M56C332215- _____ 15"L
- M56C332218- _____ 18"L
- M56C332221- _____ 21"L
- M56C332224- _____ 24"L

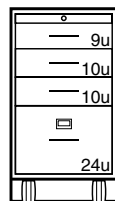
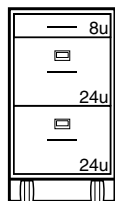

- M71C332215- _____ 15"L
- M71C332218- _____ 18"L
- M71C332221- _____ 21"L
- M71C332224- _____ 24"L

- M68C332215- _____ 15"L
- M68C332218- _____ 18"L
- M68C332221- _____ 21"L
- M68C332224- _____ 24"L

Illustrations and specifications are based on most current design and production information available. Kewaunee reserves the right to make changes at any time without notice.

Mobile Cabinet Tops & Accessories

Specifications:

1" Thick Mobile Cabinet Tops are available in three depths, 22", 23", or 24" and three materials: Kemresin, Phenolic Resin or Plastic Laminate. They may be used on any Mobile

Cabinet and add 1" to the overall height of the cabinets. All edges of top are finished.

1" Thick — Mobile Cabinet Top (adds 1" to height of Mobile Cabinet)

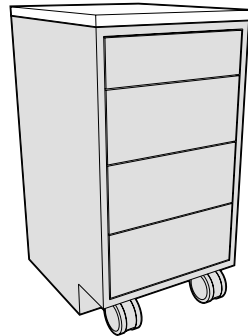

22" Deep flush to front of case

Length	Kemresin®	Kemresin Colors	Black Phenolic Resin	Black Plastic Laminate
15"	F94R2215-00-	BK = Black	F94T2215-00	F94P2215-00
18"	F94R2218-00-	GR = Grey	F94T2218-00	F94P2218-00
21"	F94R2221-00-	PT = Putty	F94T2221-00	F94P2221-00
24"	F94R2224-00-	SL = Slate	F94T2224-00	F94P2224-00
30"	F94R2230-00-		F94T2230-00	F94P2230-00
36"	F94R2236-00-		F94T2236-00	F94P2236-00
42"	F94R2242-00-		F94T2242-00	F94P2242-00
48"	F94R2248-00-		F94T2248-00	F94P2248-00

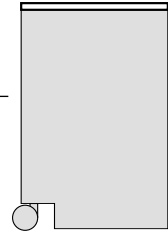

Inset Cabinet End View

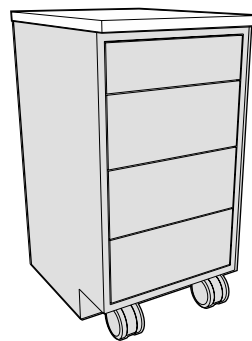

23" Deep flush to overlay door/drawer fronts - 1" overhang of case

Length	Kemresin®	Kemresin Colors	Black Phenolic Resin	Black Plastic Laminate
15"	F94R2315-00-	BK = Black	F94T2315-00	F94P2315-00
18"	F94R2318-00-	GR = Grey	F94T2318-00	F94P2318-00
21"	F94R2321-00-	PT = Putty	F94T2321-00	F94P2321-00
24"	F94R2324-00-	SL = Slate	F94T2324-00	F94P2324-00
30"	F94R2330-00-		F94T2330-00	F94P2330-00
36"	F94R2336-00-		F94T2336-00	F94P2336-00
42"	F94R2342-00-		F94T2342-00	F94P2342-00
48"	F94R2348-00-		F94T2348-00	F94P2348-00

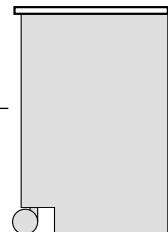

Inset Cabinet End View

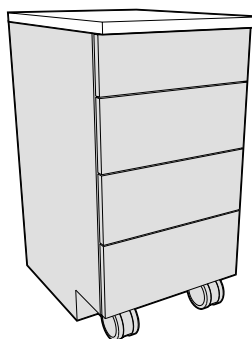

24" Deep 1" overhang of overlay door/drawer fronts

Length	Kemresin®	Kemresin Colors	Black Phenolic Resin	Black Plastic Laminate
15"	F94R2415-00-	BK = Black	F94T2415-00	F94P2415-00
18"	F94R2418-00-	GR = Grey	F94T2418-00	F94P2418-00
21"	F94R2421-00-	PT = Putty	F94T2421-00	F94P2421-00
24"	F94R2424-00-	SL = Slate	F94T2424-00	F94P2424-00
30"	F94R2430-00-		F94T2430-00	F94P2430-00
36"	F94R2436-00-		F94T2436-00	F94P2436-00
42"	F94R2442-00-		F94T2442-00	F94P2442-00
48"	F94R2448-00-		F94T2448-00	F94P2448-00

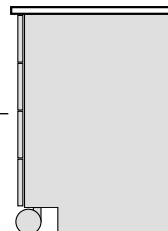

Overlay Cabinet End View

Mobile Cabinet Tops & Accessories

Specifications:

Steel Mobile Cabinet Tops are fabricated from 18 gauge steel and finished to match the cabinet. They are designed for Steel Mobile Cabinets only.

Mobile Cabinet Grabbar allows easier movement and relocation of mobile cabinets. Fabricated from powder coated steel or stainless steel, they may be used on any

Mobile Cabinet, with or without Tops. Bars must be attached in field with supplied screws and/or bolts.

22" Deep — Steel — Mobile Cabinet Top (adds less than 1/4" to height of Mobile Cabinet)

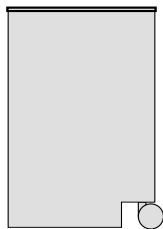
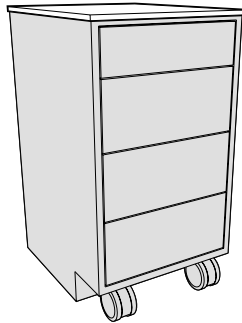

*Inset Cabinet
End View*

22" Deep Top
for Steel Mobile Cabinets only

Lg	Painted Steel	Stainless Steel
15"	F94M2215-00	F94S2215-00
18"	F94M2218-00	F94S2218-00
21"	F94M2221-00	F94S2221-00
24"	F94M2224-00	F94S2224-00
30"	F94M2230-00	F94S2230-00
36"	F94M2236-00	F94S2236-00
42"	F94M2242-00	F94S2242-00
48"	F94M2248-00	F94S2248-00

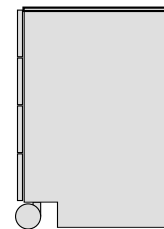

*Overlay Cabinet
End View*

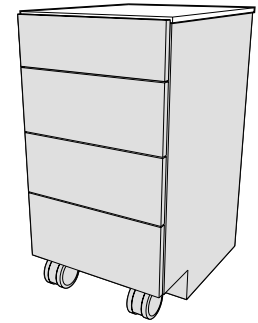

23" Deep — Steel — Mobile Cabinet Top (adds 1/2" to height of Mobile Cabinet)

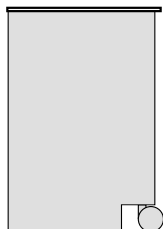
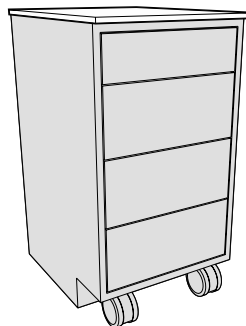

*Inset Cabinet
End View*

23" Deep Top
for Steel Mobile Cabinets only

Lg	Painted Steel	Stainless Steel
15"	F94M2315-00	F94S2315-00
18"	F94M2318-00	F94S2318-00
21"	F94M2321-00	F94S2321-00
24"	F94M2324-00	F94S2324-00
30"	F94M2330-00	F94S2330-00
36"	F94M2336-00	F94S2336-00
42"	F94M2342-00	F94S2342-00
48"	F94M2348-00	F94S2348-00

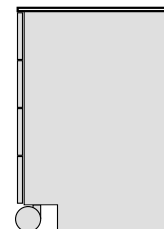

*Overlay Cabinet
End View*

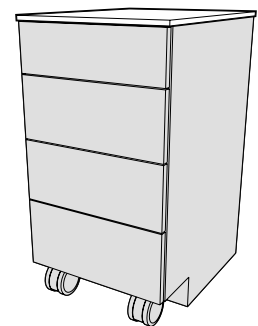

Mobile Cabinet Grabbar

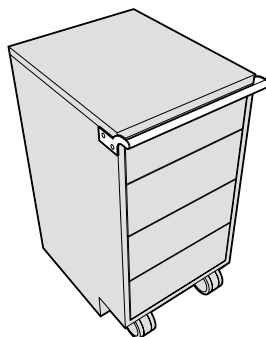

Length	Painted Steel	Stainless Steel
15"	F73M0015-00	F73S0015-00
18"	F73M0018-00	F73S0018-00
21"	F73M0021-00	F73S0021-00
24"	F73M0024-00	F73S0024-00

